

# TECHNICAL HANDBOOK

Fire stopping of service penetrations  
in timber constructions

1<sup>st</sup> edition January 2020



# Foreword

The use of solid wooden or cross-laminated timber constructions, walls and floors, is getting more and more popular, hence the need for proper solutions to protect them from fires burning through and with surface protection to hinder the spread of flames. This is especially essential as these constructions are now used as part of the fire compartmentation inside a building.

Polyseam has started a test program which has included several constructions in both timber walls and floors with service penetrations and also paints for surface protection.

The timber walls and floors we have tested do resist fires for a certain time period. The walls were 100mm thick, the floors were 150mm thick and they were constructed with materials from randomly chosen manufacturers. All of them had in common an integrity failure between 90 and 125 minutes and during this time the temperatures on the un-exposed faces were relatively low. They can therefore be considered suitable to replace fire rated drywalls and hollow timber floors.

But the significant and real difference from a concrete or masonry construction is that these constructions collapse completely once the fire has burned through. Polyseam would therefore advise that solid timber walls and floors should only be used as secondary loadbearing structures and that they are connected to a primary loadbearing structure made of reinforced concrete, fire protected structural steel or perhaps glulam timber, especially in buildings with more than two floors.

In high-rise buildings, one should also consider using only concrete floors and secure every floor against fire spreading from one floor to the next through internal apertures and via façades. Furthermore, staircases and

lifts should be encapsulated in fire compartments made of masonry or concrete always securing at least two escape routes, one on each side of the building.

In addition, in larger rooms, in areas with plenty of people are gathered, or in escape routes; the wall and ceiling surfaces should be protected against spread of flame. This is quite simple to achieve by using a fire protection acrylic paint instead of a normal paint, which can also be tinted in a colour of choice, or as a transparent paint to retain the original wooden surface in both matt and gloss finishes. Special precautions are of course also necessary to avoid the spread of fire from one building to the next.

Considering the above, it is therefore important that with the use of solid wooden or cross-laminated timber constructions, the fire strategy is thought through properly. But by building these buildings to withstand the worst possible fire scenarios, it is in my view quite possible to ensure they are safe and environmentally friendly.

Kjetil Bogstad  
Handbook editor & CEO of Polyseam



*'Treet' – Currently the World's second tallest timber (hybrid) high-rise building, in Bergen, Norway*

# Content

## **Which products should be used for fire stopping?**

Linear seals and penetrating services..... Page 4

## **General rules for fire sealing timber constructions**

Aperture sizes and layouts..... Page 5

Service sizes..... Page 6

Fire classifications..... Page 6

Pipe end configurations..... Page 7

Supporting constructions and service supports..... Page 8

## **Normal on-site problems and solutions**

Frequently asked questions..... Pages 9 – 10

## **Technical solutions**

Appendix I – Blank seals & service penetration solutions in floors..... Pages 11 – 24

Appendix II – Blank seals & service penetration solutions in walls..... Pages 25 – 40

**Index to technical solutions**..... Pages 41

# Which products should be used for fire stopping?

In timber constructions, it is common to use circular holes that fit the passing services to retain the constructional strength. Products for fire stopping have therefore been chosen accordingly with the use of Protecta® fire resistant sealants, collars and service transits designed for a small annular gap around the services passing through.

With cable ladders or cable trays, it is also common to have circular holes, side by side, with the ladder or tray discontinued so it does not pass through the construction. In these situations, it is important that the ladder or tray is supported to a nearby construction, to resist fire, so they do not collapse during the required fire resistance period and damaging the fire seal.



Typical sample of penetrating services with annular gap widths between 10 and 20mm

## Product Selector - Linear Seals

Properties	Construction	Seal Size	Product
<b>Normal</b>	Walls and floors	Up to 30mm wide	Protecta FR Acrylic
<b>Water proof and high movement</b>		Up to 30mm wide	Protecta FR IPT

## Product Selector - Penetrating Services

Seal Size	Services	Product(s)
<b>Annular gap between 10 and 20mm wide</b>	Cables	Protecta FR Acrylic and Service Coat FR-1, or Protecta FR Service Transit
	Metal pipes; mineral wool insulations	Protecta FR Acrylic
	Metal pipes; combustible insulations	Protecta FR Graphite
	Plastic pipes	Protecta FR Acrylic and/or FR Collar
	Ventilation ducts	Protecta FR Acrylic and FR Damper

# General rules for fire sealing timber constructions

## Aperture sizes and layouts

Apertures for fire seals tested with Protecta products have been designed to be the same as recommended by the manufacturers of timber constructions. These are normally circular and fitted to each service penetration to keep the constructional strength as high as possible.

The below rules should be followed when the apertures for the services are drilled. Where cable trays or ladders are used, these should be discontinued on each side of the constructions, so only single or bundled cables pass through circular apertures placed side-by-side. Please make sure any trays or ladders have fire resistant supports to keep cables from falling down for at least 2 hours.

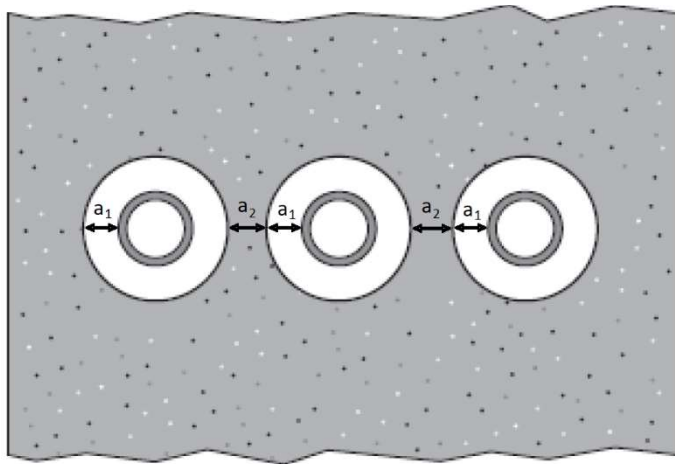

### Rules; single apertures, or in a group

1. A group can consist of multiple linear placed apertures.
2. In walls, apertures within a group must be placed horizontally.
3.  $a_1$  must be between 10 and 20 mm.
4.  $a_2$  can be 0 mm or anything above (remember to allocate space for pipe insulations or collars).
5. The minimum distance to the next group must be 200 mm.

Additional guidance from the manufacturer of the construction must also be followed.

## Service sizes

The test standard (EN1366-3) groups services to be tested for approval. For instance, all cables in the group up to a certain diameter must be tested otherwise, approval is only granted for the exact specimen tested, and this has no practical value.

For cables, there are many groups to test to obtain full approval. For example to obtain approval for all cables up to 21mm diameter, it is necessary to test the following cables: type A1, A2, A3 (A cables are 5 x 1.5mm<sup>2</sup>) and B (1 x 95mm<sup>2</sup>). The position of the cables in the test is also subject to how the cables are allowed to be positioned in practice.

Our specifications for installation are simplified to allow the installation to be performed correctly and with the least complexity, however testing to achieve the specifications is anything but simple. In general we specify service sizes with the symbol  $\leq$  in front. Without this symbol, the size of the service is exactly as specified. The same can be said for pipes. For metal pipes testing consists of a certain design group which includes pipe diameter and wall thickness. However, where we do not specify this, it is because we have tested all the different wall thicknesses available. For plastic pipes testing also includes the different plastics, eg: PVC, PE and so on, and wall thicknesses are specified unless the pipe is specific.

## Fire classifications

In fire stopping, only a few letters are used to indicate the result and what protection the installation gives.

**E - Integrity**, the time it takes for fire to physically spread through a fire seal. At the point of failure one can see the glow of the fire through the seal, flames coming through or via a cotton pad which catches fire when held close to the seal by the test technician. This is the simplest classification to achieve.

**I - Insulation**, the temperature, measured on the non-fire side has increased by 180°C on either the fire seal or the services. This is measured through many thermocouples placed in strategic locations. The intention is to replicate the lowest possible temperature that can actually start a fire, even though the fire itself has not passed through the fire seal. This is the more difficult classification to achieve.

The letters are followed by a number, which is how long in minutes the integrity and insulation were maintained. For instance, the classification **E 60** is integrity for one hour, whilst **EI 120** is both integrity and insulation for two hours.

**NB.** Polyseam recommends that both E & I are used in classifications for timber constructions, as the constructions are combustible.

## Pipe end configurations

When testing pipes, one can choose not to cap (or close) or to cap the pipe inside or outside the furnace. The configuration chosen depends on the intended application of the pipe and/or the installation environment. The code defining if a pipe is capped is stated after the fire classification. For instance EI 60 C/U means the pipe was capped inside the furnace, and uncapped outside the furnace.

### Field of application rules for pipe end configuration:

		Tested			
		U/U	C/U	U/C	C/C
Covered	U/U	-	NO	NO	NO
	C/U	YES	-	NO	NO
	U/C	YES	YES	-	NO
	C/C	YES	YES	YES	-

### Our engineering judgment based on EN 1366-3:2009:

Intended use of pipe	Pipe end condition	
Rainwater pipe, plastic	At drainage	U/U <sup>1)</sup>
	Not at drainage	C/C <sup>2)</sup>
Drainage or sewage pipe, plastic	Ventilated drain	U/U <sup>1)</sup>
	Unventilated drain	U/C <sup>1)</sup>
	Drain w/water trap	U/C <sup>1)</sup>
	Not at drainage	C/C <sup>2)</sup>
Pipe in closed circuit (water, gas, air, electricity etc.)	C/C <sup>2) 3)</sup>	
Flue gas recovery system pipe, plastic	U/C <sup>1)</sup>	
Pipe with open ends and ≥ 50cm length on both sides, plastic	U/U <sup>2)</sup>	
Pipe supported by suspension system, metal	Fire rated support	C/U <sup>1)</sup>
	Non-fire rated	U/C <sup>1)</sup>
Waste disposal shaft pipe, metal	U/C <sup>1)</sup>	

<sup>1)</sup> Stated in EN 1366-3:2009. <sup>2)</sup> Polyseam's judgment based on tests. <sup>3)</sup> Metal pipes should have fire rated support.



## Supporting constructions and service supports

The timber supporting constructions (fire rated walls and floors) should be tested and classified in accordance with EN 13501-2 for the required fire resistance period.

Services in floors should have the first support located 250mm from the top face, and services in walls should have the first support located 270mm from both faces of the wall. Thereafter the services should be supported according to the support system manufacturer's installation instructions.



*Test of a timber floor with service penetrations fire sealed with Protecta products*



*Fire exposed side of a timber construction tested with Protecta products*



# FAQ's

## GENERAL

**Q:** *What certifications are available?*

**A:** The Protecta® fire stopping range has ETA certifications and the CE-mark for Europe and Africa, UL-EU International certifications for Asia and South America and local certifications for the United Arab Emirates, New Zealand and Australia.

**Q:** *Where are the products manufactured?*

**A:** The Protecta® range is manufactured at the Polyseam factory in Huddersfield, United Kingdom.

## CONSTRUCTIONS

**Q:** *I have a fire seal in a floor, can I use the approvals for a wall?*

**A:** No. The EuroNorm states that fire seals in floors have to be tested and approved independently from walls.

**Q:** *Can approvals for drywalls be used in timber walls?*

**A:** No. The EuroNorm does not allow this. All timber constructions must be tested and certified separately to other types of constructions.

**Q:** *I am to do a fire seal in a swimming pool area and need something moisture proof, what should I use?*

**A:** For smaller seals you can use the Protecta FR IPT sealant. For larger seals you can use Protecta FR Board, but after you have sealed the gaps and openings with FR Acrylic, apply a layer of FR Coating on top of the acrylic.

## FIRE SEALS

**Q:** *A solution states 25mm depth of Protecta FR Acrylic on 25mm backing of stonewool, can I instead seal with 50mm FR Acrylic and skip the backing?*

**A:** Yes, the FR Acrylic will give better fire resistance than the stonewool backing material so if the total depth is the same or greater this is ok.

**Q:** *There is a solution for a double sided seal with FR Acrylic at 25mm depth in a timber wall. Can I instead seal this single sided at 50mm depth?*

**A:** No. The fire seal will be weaker as the penetration speed of the fire will increase during heating of the material. With a double sided fire seal the fire has to effectively 'start again' when it meets the second seal.

**Q:** *It is stated that I use stonewool backing with Protecta FR Acrylic, can I instead use Protecta Backing material?*

**A:** Yes, the Protecta backing is made of AES fibre which has greater fire resistant than stonewool. However, if Protecta Backing is stated, you cannot use a stonewool backing.

## FAQ's

**Q:** *I have a special fire seal that is not mentioned in any of the solutions, what do I do?*

**A:** Please contact us and we will assess if we can make an Engineering Judgment.

### CABLES

**Q:** *The instructions mention cables, but does that include all types of cables?*

**A:** Yes. We have tested groups of cables which gives approvals for all kinds, including aluminium, copper and fibre optic cables.

### PIPES

**Q:** *I have a penetrating pipe made of iron, but it is not mentioned in the instructions?*

**A:** Iron is the base metal of steel, so use the instructions for steel pipes.

**Q:** *I am to fire seal a PE-HD (or HD-PE) pipe, can I use the instructions for PE pipes?*

**A:** Yes. You can fire seal all PE pipes that are manufactured to EN 1519-1, EN 12201-2 and EN 12666-1. This normally includes LD-PE, MD-PE, HD-PE and PE-X pipes.

**Q:** *It is stated 'alupex' pipes in the instructions; can I use Geberit Mepla MLC pipes?*

**A:** Yes. Alupex is a general term for composite aluminium pipes. They consist of an aluminium core that is covered on the inner and outer sides with thin plastic. Some alupex pipes on the market are:

- FRÄNKISCHE alpex F50 PROFI
- GEBERIT Mepla MLC
- JRG Sanipex MT
- KE KELIT Kelox
- REHAU Rautitan stabil
- TECEflex
- UPONOR MLC
- VIEGA Sanfix Fosta

**Q:** *I am to fire seal a Blazemaster cPVC pipe but I have heard it reacts with fire stopping products?*

**A:** Protecta FR Acrylic should be used; it has been independently tested and does not react with BlazeMaster or other cPVC pipes.

# Appendix I

-

## Blank seals & service penetration solutions in floors

Installation Instructions

1. Before installing Protecta® FR Acrylic ensure that the surface of surrounding construction is free from all loose contaminants, dust and grease.
2. Install the backing material. Cut this slightly oversize and insert into the gap ensuring a tight friction fit. Ensure correct depth is achieved.
3. Fill the gap or joint with Protecta® FR Acrylic on both sides to the required depth.
4. Apply the sealant generously to prevent air bubbles. Finish the bead with a moist spatula, pallet knife or brush.
5. Protecta® FR Acrylic can be over-painted with most emulsion or alkyd (gloss) paints.

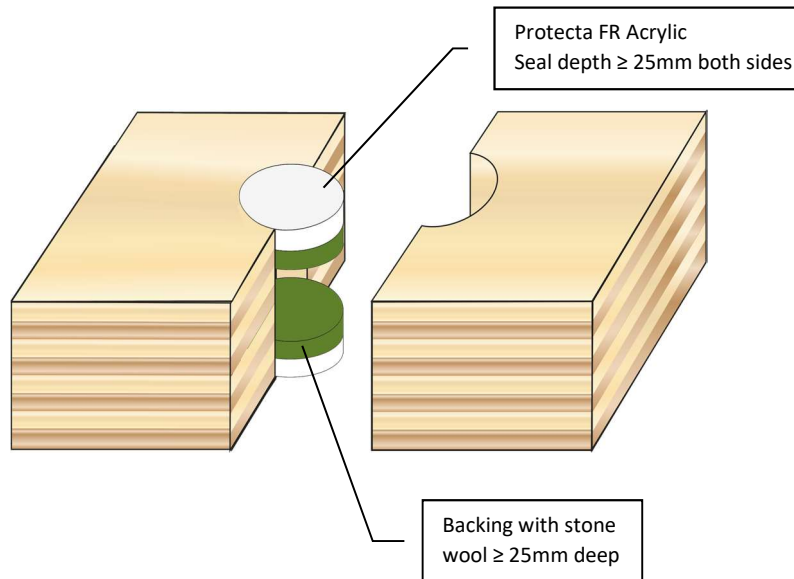

Client:

Job Title:

<b>Products</b>	Protecta FR Acrylic Stone wool backing ≥ 33 kg/m <sup>3</sup>
<b>Application</b>	Fire stopping of blank seals in timber floors
<b>Construction</b>	Minimum floor thickness of 150 mm and comprise solid wood or cross-laminated timber

<b>Fire, Sound and Air classifications</b>	
Blank seal ≤ Ø220mm	EI 120 & E 120
Reaction to fire	B-s1,d0
Sound reduction	Rw 62 dB
Pressure with zero leakage	Min. 200 Pa

**Protecta**<sup>®</sup>  
 Polyseam Ltd, 15 St Andrews Road,  
 Huddersfield, West Yorkshire, HD1 6SB  
 Tel: +44 (0) 148 4421036  
 Email: post.uk@polyseam.com



As a part of our policy of on-going product development and testing, we reserve the right to modify, alter or change product specifications without giving notice. All information contained in this document is given in good faith and is provided for guidance only. Any drawings provided are for illustrative purposes only. As Polyseam has no control over the methods or competence of installation and of prevailing site conditions, no warranties, expressed or implied, is intended to be given as to the actual performance of the product mentioned or referred to herein and no liability whatsoever will be accepted for any loss, damage or injury arising from the use of the information given.

For all technical details on the products specified please refer to the technical data sheets that can be found on [www.protecta.eu](http://www.protecta.eu)

Signed and approved:

Sheet size: <b>A4</b>	Drawn date & no: 5/1/20
Scale: <b>NTS</b>	Drawn by: K.B

Installation Instructions

1. Before installing Protecta® FR Acrylic ensure that the surface of all service penetrations and surrounding construction is free from all loose contaminants, dust and grease.
2. Install the backing material. Cut this slightly oversize and insert into the gap ensuring a tight friction fit. Ensure correct depth is achieved.
3. Fill the gap or joint with Protecta® FR Acrylic on both sides to the required depth.
4. Apply the sealant generously to prevent air bubbles. Finish the bead with a moist spatula, pallet knife or brush.
5. Coat the cable on the top side with Protecta® Service Coat FR-1 to the required length and thickness.
6. Protecta® FR Acrylic can be over-painted with most emulsion or alkyd (gloss) paints.

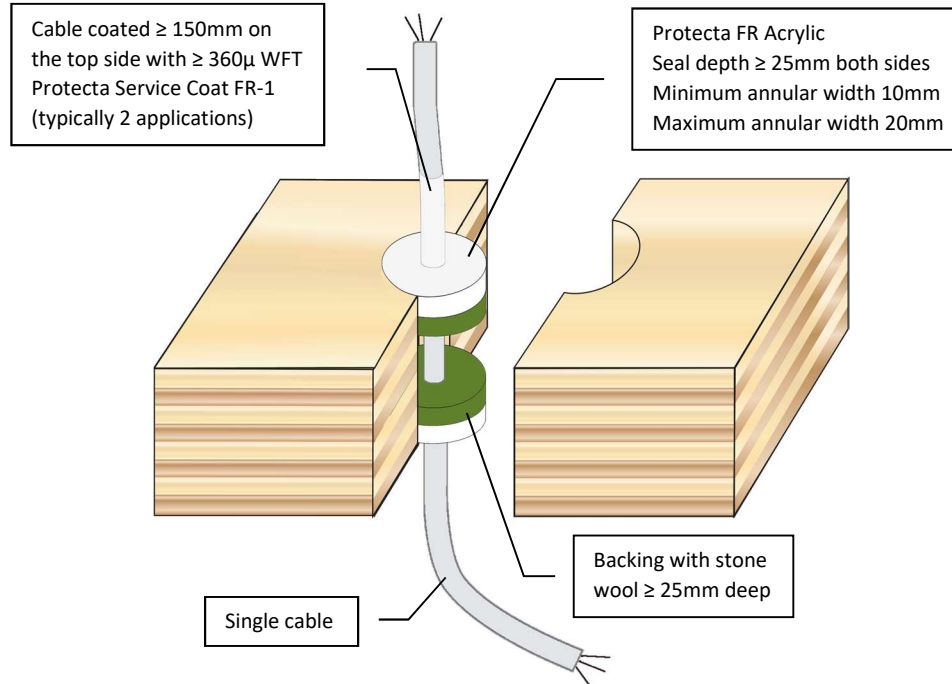

Client:

Job Title:

<b>Products</b>	Protecta FR Acrylic Protecta Service Coat FR-1 Stone wool backing ≥ 33 kg/m <sup>3</sup>
<b>Application</b>	Fire stopping of cables in timber floors
<b>Construction</b>	Minimum floor thickness of 150 mm and comprise solid wood or cross-laminated timber

<b>Fire, Sound and Air classifications</b>	
Cable ≤ Ø21mm	EI 90 & E 120
Cable ≤ Ø50mm	EI 45 & E 120
Reaction to fire (seal only)	B-s1,d0
Sound reduction (seal only)	Rw 62 dB
Pressure with zero leakage	Min. 200 Pa

**Protecta**<sup>®</sup>  
Polyseam Ltd, 15 St Andrews Road,  
Huddersfield, West Yorkshire, HD1 6SB  
Tel: +44 (0) 148 4421036  
Email: post.uk@polyseam.com



As a part of our policy of on-going product development and testing, we reserve the right to modify, alter or change product specifications without giving notice. All information contained in this document is given in good faith and is provided for guidance only. Any drawings provided are for illustrative purposes only. As Polyseam has no control over the methods or competence of installation and of prevailing site conditions, no warranties, expressed or implied, is intended to be given as to the actual performance of the product mentioned or referred to herein and no liability whatsoever will be accepted for any loss, damage or injury arising from the use of the information given.

For all technical details on the products specified please refer to the technical data sheets that can be found on [www.protecta.eu](http://www.protecta.eu)

Signed and approved:

Sheet size: <b>A4</b>	Drawn date & no: 3/1/20
Scale: <b>NTS</b>	Drawn by: K.B

Installation Instructions

1. Before installing Protecta® FR Acrylic ensure that the surface of all service penetrations and surrounding construction is free from all loose contaminants, dust and grease.
2. Install the backing material. Cut this slightly oversize and insert into the gap ensuring a tight friction fit. Ensure correct depth is achieved.
3. Fill the gap or joint with Protecta® FR Acrylic on both sides to the required depth.
4. Apply the sealant generously to prevent air bubbles. Finish the bead with a moist spatula, pallet knife or brush.
5. Coat the cable bundle on the top side with Protecta® Service Coat FR-1 to the required length and thickness.
6. Protecta® FR Acrylic can be over-painted with most emulsion or alkyd (gloss) paints.

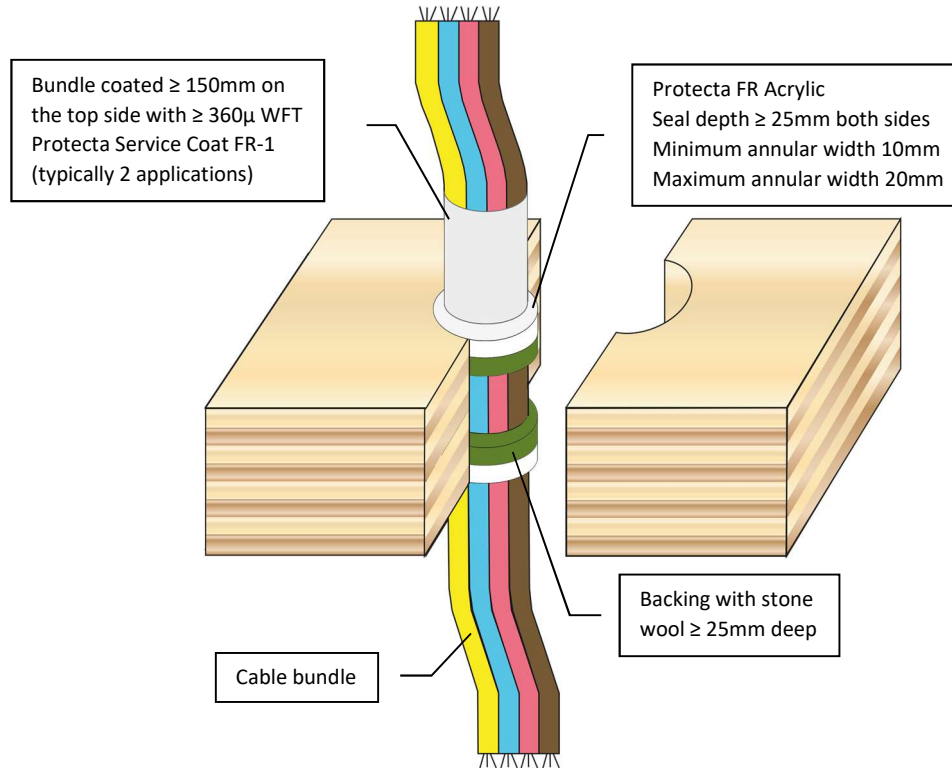

Client:

Job Title:

<b>Products</b>	Protecta FR Acrylic Protecta Service Coat FR-1 Stone wool backing ≥ 33 kg/m <sup>3</sup>
<b>Application</b>	Fire stopping of cable bundles in timber floors
<b>Construction</b>	Minimum floor thickness of 150 mm and comprise solid wood or cross-laminated timber

<b>Fire, Sound and Air classifications</b>	
Cables ≤ Ø21mm in a bundle ≤ Ø100mm	EI 90 & E 120
Reaction to fire (seal only)	B-s1,d0
Sound reduction (seal only)	Rw 62 dB
Pressure with zero leakage	Min. 200 Pa



Polyseam Ltd, 15 St Andrews Road,  
Huddersfield, West Yorkshire, HD1 6SB  
Tel: +44 (0) 148 4421036  
Email: post.uk@polyseam.com

As a part of our policy of on-going product development and testing, we reserve the right to modify, alter or change product specifications without giving notice. All information contained in this document is given in good faith and is provided for guidance only. Any drawings provided are for illustrative purposes only. As Polyseam has no control over the methods or competence of installation and of prevailing site conditions, no warranties, expressed or implied, is intended to be given as to the actual performance of the product mentioned or referred to herein and no liability whatsoever will be accepted for any loss, damage or injury arising from the use of the information given.

For all technical details on the products specified please refer to the technical data sheets that can be found on [www.protecta.eu](http://www.protecta.eu)

Signed and approved:

Sheet size: <b>A4</b>	Drawn date & no: 3/1/20
Scale: <b>NTS</b>	Drawn by: K.B

Installation Instructions

1. Before installing Protecta® FR Service Transit ensure that the surface of all service penetrations and surrounding construction is free from all loose contaminants, dust and grease.
2. Install the backing material and lock the Service Transit in position. Cut this slightly oversize and insert into the gap ensuring a tight friction fit. Ensure correct depth is achieved and that the centre point of the transit is located mid-depth in the floor.
3. Fill the gap or joint with Protecta® FR Acrylic on both sides to the required depth.
4. Apply the sealant generously to prevent air bubbles. Finish the bead with a moist spatula, pallet knife or brush.
5. Before cables and/or plastic pipes are inserted through the Service Transit, remove the fibre plug from the middle of the Service Transit. After the insertion of services is completed, ensure that the fibre plug is refitted and positioned correctly around the services in the middle of the Service Transit, leaving no openings so a cold smoke barrier is achieved.
6. Make sure labels with retrofit instructions are placed near the Service Transit on both sides after installation, so future service installations are completed correctly by reinstating the fibre plug.
7. Protecta® FR Acrylic can be over-painted with most emulsion or alkyd (gloss) paints.

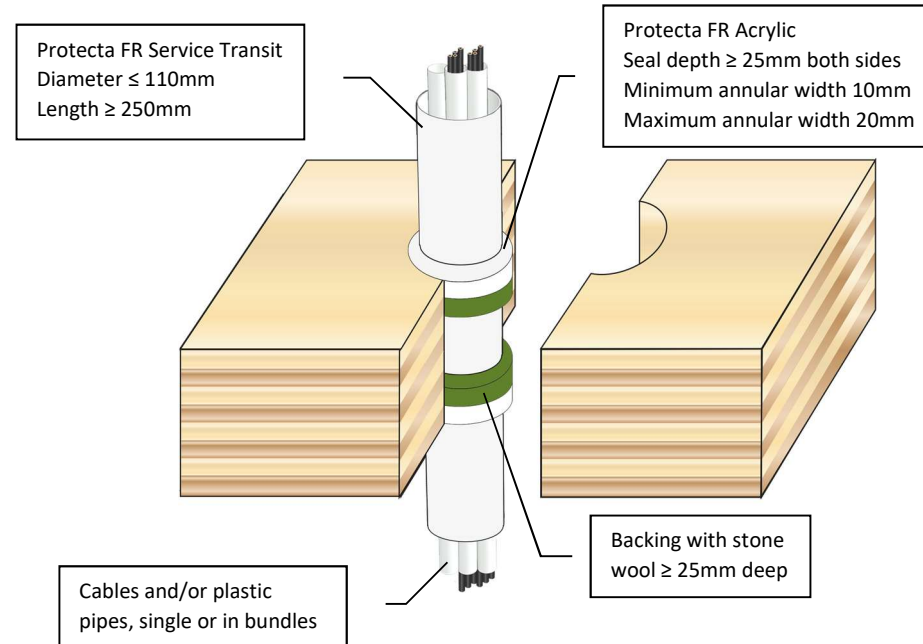

Client:

Job Title:

<b>Products</b>	Protecta FR Acrylic Protecta FR Service Transit Stone wool backing ≥ 33 kg/m <sup>3</sup>
<b>Application</b>	Fire stopping of cables and plastic pipes in timber floors
<b>Construction</b>	Minimum floor thickness of 150 mm and comprise solid wood or cross-laminated timber

<b>Fire and Sound classifications</b>	
Empty, or with cables ≤ Ø21mm	EI 120 & E 120
Cables ≤ Ø50mm	EI 60 & E 120
Cables ≤ Ø80mm	EI 60 & E 90
Plastic pipes ≤ Ø32mm, empty or with penetrating cables ≤ Ø21mm, single or in bundles	EI 120 & E 120
Sound reduction	Rw 42 dB

**Protecta®**  
Polyseam Ltd, 15 St Andrews Road,  
Huddersfield, West Yorkshire, HD1 6SB  
Tel: +44 (0) 148 4421036  
Email: post.uk@polyseam.com



As a part of our policy of on-going product development and testing, we reserve the right to modify, alter or change product specifications without giving notice. All information contained in this document is given in good faith and is provided for guidance only. Any drawings provided are for illustrative purposes only. As Polyseam has no control over the methods or competence of installation and of prevailing site conditions, no warranties, expressed or implied, is intended to be given as to the actual performance of the product mentioned or referred to herein and no liability whatsoever will be accepted for any loss, damage or injury arising from the use of the information given.

For all technical details on the products specified please refer to the technical data sheets that can be found on [www.protecta.eu](http://www.protecta.eu)

Signed and approved:

Sheet size: <b>A4</b>	Drawn date & no: 3/1/20
Scale: <b>NTS</b>	Drawn by: K.B

Installation Instructions

1. Before installing Protecta® FR Acrylic ensure that the surface of all service penetrations and surrounding construction is free from all loose contaminants, dust and grease.
2. As Protecta® FR Acrylic is water based, in cases where corrosion protection is a problem; some metals may require a barrier between the sealant and the metal surface prior to this installation.
3. Install the backing material. Cut this slightly oversize and insert into the gap ensuring a tight friction fit. Ensure correct depth is achieved.
4. Fill the gap or joint with Protecta® FR Acrylic on both sides to the required depth.
5. Apply the sealant generously to prevent air bubbles. Finish the bead with a moist spatula, pallet knife or brush.
6. Protecta® FR Acrylic can be over-painted with most emulsion or alkyd (gloss) paints.

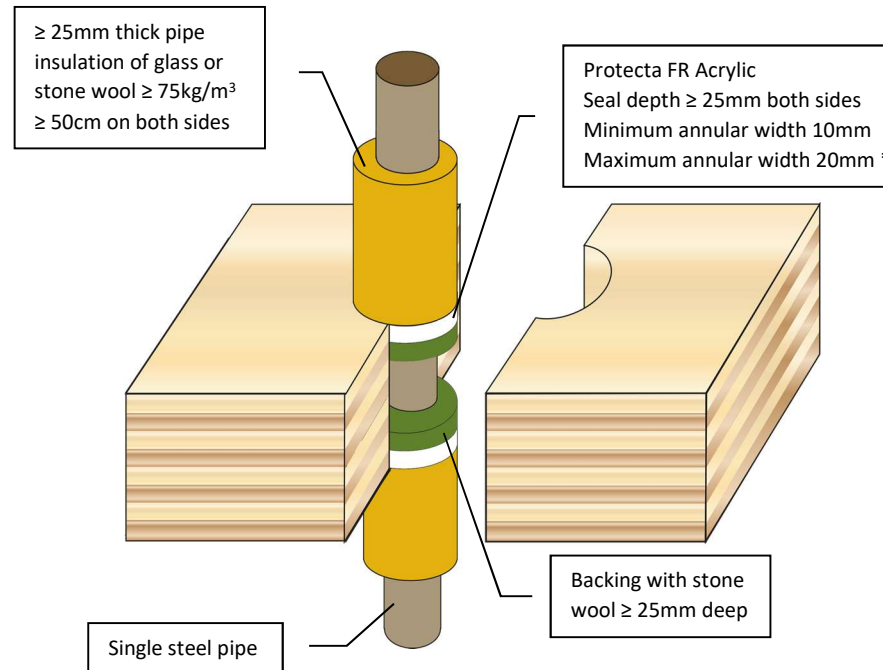

\*) For pipes above Ø180mm, the annular width should be 10mm



As a part of our policy of on-going product development and testing, we reserve the right to modify, alter or change product specifications without giving notice. All information contained in this document is given in good faith and is provided for guidance only. Any drawings provided are for illustrative purposes only. As Polyseam has no control over the methods or competence of installation and of prevailing site conditions, no warranties, expressed or implied, is intended to be given as to the actual performance of the product mentioned or referred to herein and no liability whatsoever will be accepted for any loss, damage or injury arising from the use of the information given.

For all technical details on the products specified please refer to the technical data sheets that can be found on [www.protecta.eu](http://www.protecta.eu)

Signed and approved:

Client:	
Job Title:	
<b>Products</b>	Protecta FR Acrylic Stone wool backing ≥ 33 kg/m <sup>3</sup>
<b>Application</b>	Fire stopping of steel pipes in timber floors
<b>Construction</b>	Minimum floor thickness of 150 mm and comprise solid wood or cross-laminated timber
<b>Fire, Sound and Air classifications</b>	
Steel pipe ≤ Ø273mm	EI 60 C/U & E 120 C/U
Reaction to fire (seal only)	B-s1,d0
Sound reduction (seal only)	Rw 62 dB
Pressure with zero leakage	Min. 200 Pa
	
Polyseam Ltd, 15 St Andrews Road, Huddersfield, West Yorkshire, HD1 6SB Tel: +44 (0) 148 4421036 Email: <a href="mailto:post.uk@polyseam.com">post.uk@polyseam.com</a>	
Sheet size: <b>A4</b>	Drawn date & no: 3/1/20
Scale: <b>NTS</b>	Drawn by: K.B



Installation Instructions

1. Before installing Protecta® FR Graphite ensure that the surface of all service penetrations and surrounding construction is free from all loose contaminants, dust and grease.
2. Install the backing material. Cut this slightly oversize and insert into the gap ensuring a tight friction fit. Ensure correct depth is achieved.
3. Fill the gap or joint with Protecta® FR Graphite on both sides to the required depth.
4. Apply the sealant generously avoiding air bubbles. Finish the bead with a moist spatula or pallet knife. Avoid excessive tooling/smoothing as this may make the seal surface wet and soft.
5. Protecta® FR Graphite can be over-painted with most emulsion or alkyd (gloss) paints.

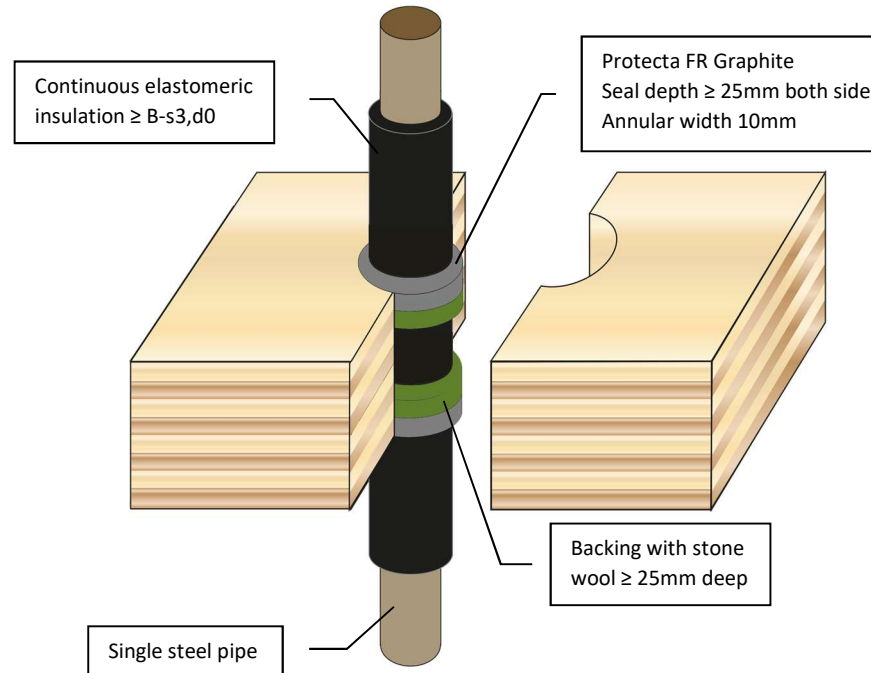

Client:

Job Title:

<b>Products</b>	Protecta FR Graphite Stone wool backing ≥ 33 kg/m <sup>3</sup>
<b>Application</b>	Fire stopping of steel pipes in timber floors
<b>Construction</b>	Minimum floor thickness of 150 mm and comprise solid wood or cross-laminated timber

**Fire and Sound classifications**

Steel pipe ≤ Ø114mm with 9 – 19mm thick pipe insulation	EI 45 C/U & E 120 C/U
Steel pipe ≤ Ø114mm with 25mm thick pipe insulation	EI 60 C/U & E 120 C/U
Reaction to fire (seal only)	B-s1,d0
Sound reduction (seal only)	Rw 53 dB



Polyseam Ltd, 15 St Andrews Road,  
Huddersfield, West Yorkshire, HD1 6SB  
Tel: +44 (0) 148 4421036  
Email: [post.uk@polyseam.com](mailto:post.uk@polyseam.com)

As a part of our policy of on-going product development and testing, we reserve the right to modify, alter or change product specifications without giving notice. All information contained in this document is given in good faith and is provided for guidance only. Any drawings provided are for illustrative purposes only. As Polyseam has no control over the methods or competence of installation and of prevailing site conditions, no warranties, expressed or implied, is intended to be given as to the actual performance of the product mentioned or referred to herein and no liability whatsoever will be accepted for any loss, damage or injury arising from the use of the information given.

For all technical details on the products specified please refer to the technical data sheets that can be found on [www.protecta.eu](http://www.protecta.eu)

Signed and approved:

Sheet size:	Drawn date & no:
<b>A4</b>	3/1/20
Scale:	Drawn by:
<b>NTS</b>	K.B

Installation Instructions

1. Before installing Protecta® FR Acrylic ensure that the surface of all service penetrations and surrounding construction is free from all loose contaminants, dust and grease.
2. As Protecta® FR Acrylic is water based, in cases where corrosion protection is a problem; some metals may require a barrier between the sealant and the metal surface prior to this installation.
3. Install the backing material. Cut this slightly oversize and insert into the gap ensuring a tight friction fit. Ensure correct depth is achieved.
4. Fill the gap or joint with Protecta® FR Acrylic on both sides to the required depth.
5. Apply the sealant generously to prevent air bubbles. Finish the bead with a moist spatula, pallet knife or brush.
6. Protecta® FR Acrylic can be over-painted with most emulsion or alkyd (gloss) paints.

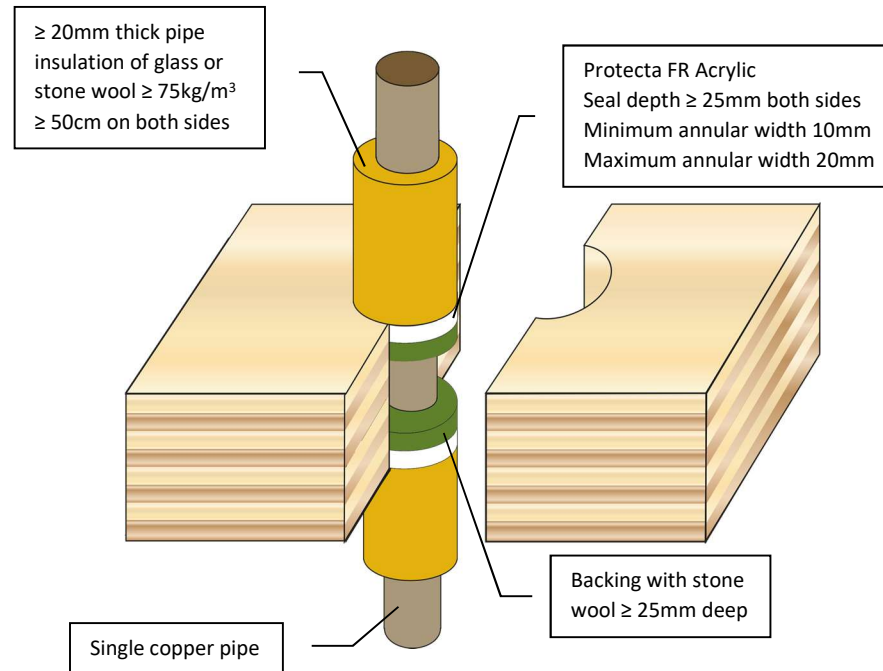

Client:

Job Title:

<b>Products</b>	Protecta FR Acrylic Stone wool backing ≥ 33 kg/m <sup>3</sup>
<b>Application</b>	Fire stopping of copper pipes in timber floors
<b>Construction</b>	Minimum floor thickness of 150 mm and comprise solid wood or cross-laminated timber

<b>Fire, Sound and Air classifications</b>	
Copper pipe ≤ Ø15mm	EI 120 C/C & E 120 C/C
Copper pipe ≤ Ø54mm	EI 90 C/C & E 120 C/C
Reaction to fire (seal only)	B-s1,d0
Sound reduction (seal only)	Rw 62 dB
Pressure with zero leakage	Min. 200 Pa



Polyseam Ltd, 15 St Andrews Road,  
Huddersfield, West Yorkshire, HD1 6SB  
Tel: +44 (0) 148 4421036  
Email: [post.uk@polyseam.com](mailto:post.uk@polyseam.com)

As a part of our policy of on-going product development and testing, we reserve the right to modify, alter or change product specifications without giving notice. All information contained in this document is given in good faith and is provided for guidance only. Any drawings provided are for illustrative purposes only. As Polyseam has no control over the methods or competence of installation and of prevailing site conditions, no warranties, expressed or implied, is intended to be given as to the actual performance of the product mentioned or referred to herein and no liability whatsoever will be accepted for any loss, damage or injury arising from the use of the information given.

For all technical details on the products specified please refer to the technical data sheets that can be found on [www.protecta.eu](http://www.protecta.eu)

Signed and approved:

Sheet size:	Drawn date & no:
<b>A4</b>	3/1/20
Scale:	Drawn by:
<b>NTS</b>	K.B

Installation Instructions

1. Before installing Protecta® FR Graphite ensure that the surface of all service penetrations and surrounding construction is free from all loose contaminants, dust and grease.
2. Install the backing material. Cut this slightly oversize and insert into the gap ensuring a tight friction fit. Ensure correct depth is achieved.
3. Fill the gap or joint with Protecta® FR Graphite on both sides to the required depth.
4. Apply the sealant generously avoiding air bubbles. Finish the bead with a moist spatula or pallet knife. Avoid excessive tooling/smoothing as this may make the seal surface wet and soft.
5. Protecta® FR Graphite can be over-painted with most emulsion or alkyd (gloss) paints.

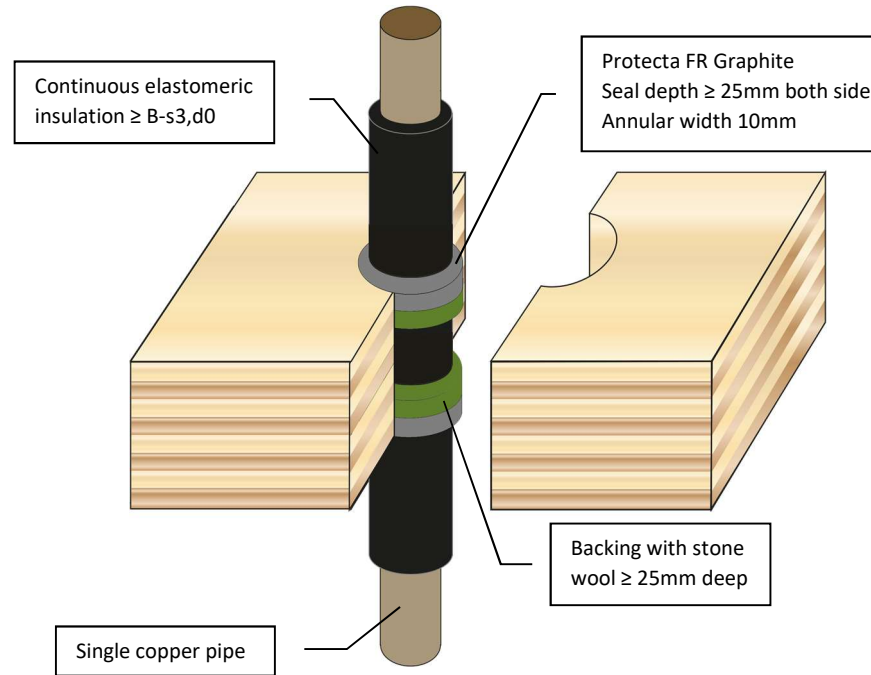

Client:

Job Title:

<b>Products</b>	Protecta FR Graphite Stone wool backing ≥ 33 kg/m <sup>3</sup>
<b>Application</b>	Fire stopping of copper pipes in timber floors
<b>Construction</b>	Minimum floor thickness of 150 mm and comprise solid wood or cross-laminated timber

<b>Fire and Sound classifications</b>	
Copper pipe ≤ Ø12mm with 9mm thick pipe insulation	EI 120 C/C & E 120 C/C
Copper pipe ≤ Ø54mm with 9mm thick pipe insulation	EI 45 C/C & E 120 C/C
Copper pipe ≤ Ø54mm with 13 – 25mm thick pipe insulation	EI 30 C/C & E 120 C/C
Reaction to fire (seal only)	B-s1,d0
Sound reduction (seal only)	Rw 53 dB

**Protecta®**  
Polyseam Ltd, 15 St Andrews Road,  
Huddersfield, West Yorkshire, HD1 6SB  
Tel: +44 (0) 148 4421036  
Email: [post.uk@polyseam.com](mailto:post.uk@polyseam.com)



As a part of our policy of on-going product development and testing, we reserve the right to modify, alter or change product specifications without giving notice. All information contained in this document is given in good faith and is provided for guidance only. Any drawings provided are for illustrative purposes only. As Polyseam has no control over the methods or competence of installation and of prevailing site conditions, no warranties, expressed or implied, is intended to be given as to the actual performance of the product mentioned or referred to herein and no liability whatsoever will be accepted for any loss, damage or injury arising from the use of the information given.

For all technical details on the products specified please refer to the technical data sheets that can be found on [www.protecta.eu](http://www.protecta.eu)

Signed and approved:

Sheet size: <b>A4</b>	Drawn date & no: 3/1/20
Scale: <b>NTS</b>	Drawn by: K.B

Installation Instructions

1. Before installing Protecta® FR Acrylic ensure that the surface of all service penetrations and surrounding construction is free from all loose contaminants, dust and grease.
2. Install the backing material. Cut this slightly oversize and insert into the gap ensuring a tight friction fit. Ensure correct depth is achieved.
3. Fill the gap or joint with Protecta® FR Acrylic on both sides to the required depth.
4. Apply the sealant generously to prevent air bubbles. Finish the bead with a moist spatula, pallet knife or brush.
5. Protecta® FR Acrylic can be over-painted with most emulsion or alkyd (gloss) paints.

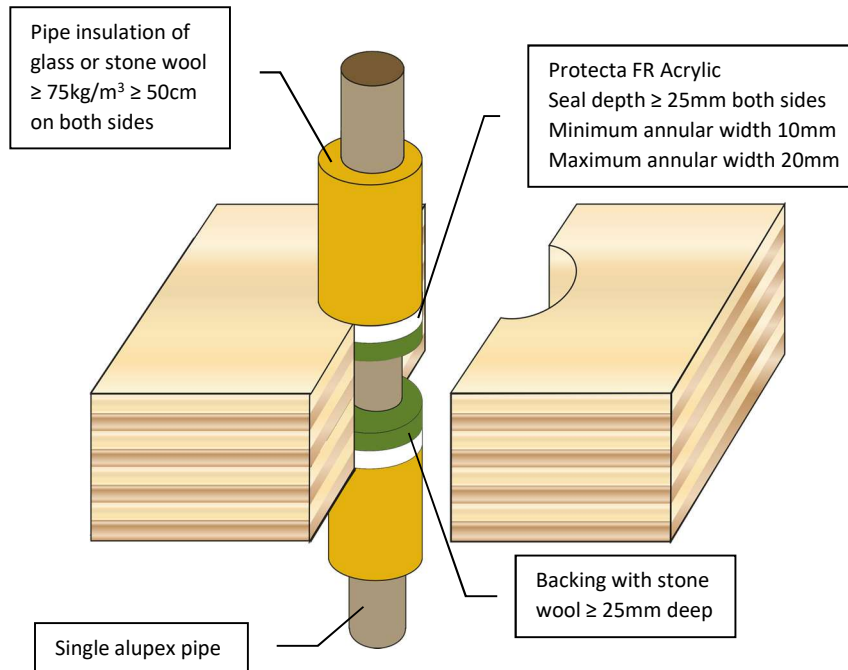

Client:

Job Title:

<b>Products</b>	Protecta FR Acrylic Stone wool backing ≥ 33 kg/m <sup>3</sup>
<b>Application</b>	Fire stopping of alupex pipes in timber floors
<b>Construction</b>	Minimum floor thickness of 150 mm and comprise solid wood or cross-laminated timber

<b>Fire, Sound and Air classifications</b>	
Alupex pipe ≤ Ø16mm with ≥ 20mm thick pipe insulation	EI 120 C/C & E 120 C/C
Alupex pipe ≤ Ø75mm with ≥ 25mm thick pipe insulation	EI 90 C/C & E 120 C/C
Reaction to fire (seal only)	B-s1,d0
Sound reduction (seal only)	Rw 62 dB
Pressure with zero leakage	Min. 200 Pa

**Protecta®**  
Polyseam Ltd, 15 St Andrews Road,  
Huddersfield, West Yorkshire, HD1 6SB  
Tel: +44 (0) 148 4421036  
Email: post.uk@polyseam.com



As a part of our policy of on-going product development and testing, we reserve the right to modify, alter or change product specifications without giving notice. All information contained in this document is given in good faith and is provided for guidance only. Any drawings provided are for illustrative purposes only. As Polyseam has no control over the methods or competence of installation and of prevailing site conditions, no warranties, expressed or implied, is intended to be given as to the actual performance of the product mentioned or referred to herein and no liability whatsoever will be accepted for any loss, damage or injury arising from the use of the information given.

For all technical details on the products specified please refer to the technical data sheets that can be found on [www.protecta.eu](http://www.protecta.eu)

Signed and approved:

Sheet size:	Drawn date & no:
<b>A4</b>	3/1/20
Scale:	Drawn by:
<b>NTS</b>	K.B

Installation Instructions

1. Before installing Protecta® FR Graphite ensure that the surface of all service penetrations and surrounding construction is free from all loose contaminants, dust and grease.
2. Install the backing material. Cut this slightly oversize and insert into the gap ensuring a tight friction fit. Ensure correct depth is achieved.
3. Fill the gap or joint with Protecta® FR Graphite on both sides to the required depth.
4. Apply the sealant generously avoiding air bubbles. Finish the bead with a moist spatula or pallet knife. Avoid excessive tooling/smoothing as this may make the seal surface wet and soft.
5. Protecta® FR Graphite can be over-painted with most emulsion or alkyd (gloss) paints.

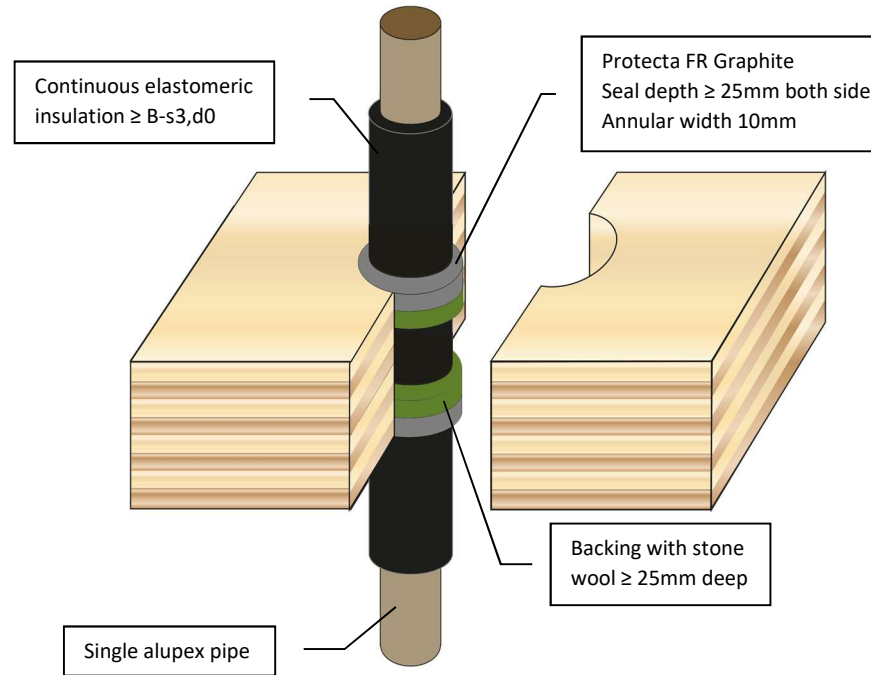

Client:

Job Title:

<b>Products</b>	Protecta FR Graphite Stone wool backing ≥ 33 kg/m <sup>3</sup>
<b>Application</b>	Fire stopping of alupex pipes in timber floors
<b>Construction</b>	Minimum floor thickness of 150 mm and comprise solid wood or cross-laminated timber

**Fire and Sound classifications**

Alupex pipe ≤ Ø16mm with 9mm thick pipe insulation	EI 120 C/C & E 120 C/C
Alupex pipe ≤ Ø75mm with 9 – 19mm thick pipe insulation	EI 60 C/C & E 120 C/C
Alupex pipe ≤ Ø75mm with 25mm thick pipe insulation	EI 90 C/C & E 120 C/C
Reaction to fire (seal only)	B-s1,d0
Sound reduction (seal only)	Rw 53 dB



Polyseam Ltd, 15 St Andrews Road,  
Huddersfield, West Yorkshire, HD1 6SB  
Tel: +44 (0) 148 4421036  
Email: [post.uk@polyseam.com](mailto:post.uk@polyseam.com)

As a part of our policy of on-going product development and testing, we reserve the right to modify, alter or change product specifications without giving notice. All information contained in this document is given in good faith and is provided for guidance only. Any drawings provided are for illustrative purposes only. As Polyseam has no control over the methods or competence of installation and of prevailing site conditions, no warranties, expressed or implied, is intended to be given as to the actual performance of the product mentioned or referred to herein and no liability whatsoever will be accepted for any loss, damage or injury arising from the use of the information given.

For all technical details on the products specified please refer to the technical data sheets that can be found on [www.protecta.eu](http://www.protecta.eu)

Signed and approved:

Sheet size: <b>A4</b>	Drawn date & no: 3/1/20
Scale: <b>NTS</b>	Drawn by: K.B

Installation Instructions

1. Before installing Protecta® FR Acrylic ensure that the surface of all service penetrations and surrounding construction is free from all loose contaminants, dust and grease.
2. Install the backing material. Cut this slightly oversize and insert into the gap ensuring a tight friction fit. Ensure correct depth is achieved.
3. Fill the gap or joint with Protecta® FR Acrylic on both sides to the required depth.
4. Apply the sealant generously to prevent air bubbles. Finish the bead with a moist spatula, pallet knife or brush.
5. Protecta® FR Acrylic can be over-painted with most emulsion or alkyd (gloss) paints.

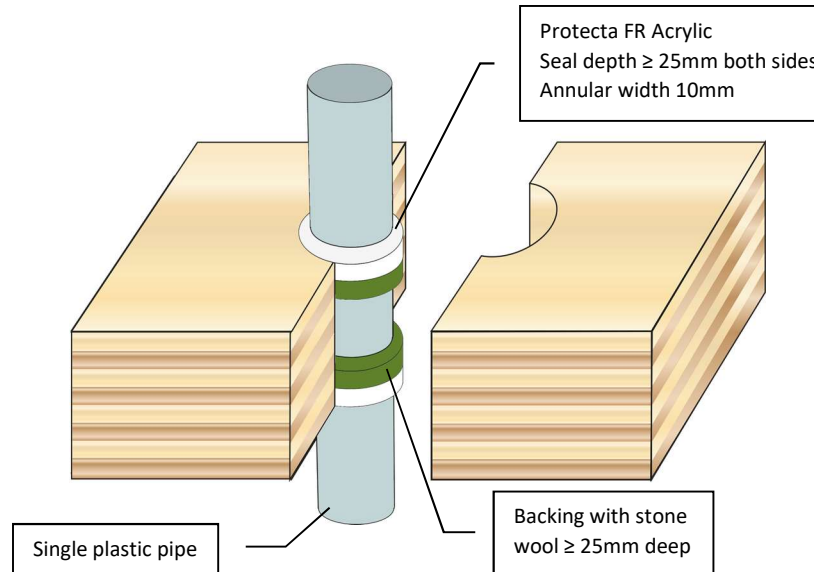

Client:

Job Title:

**Products** Protecta FR Acrylic  
Stone wool backing ≥ 33 kg/m<sup>3</sup>  
**Application** Fire stopping of plastic pipes in timber floors  
**Construction** Minimum floor thickness of 150 mm and comprise solid wood or cross-laminated timber

**Fire, Sound and Air classifications**

PVC-U or PVC-C pipe ≤ Ø32mm with wall thickness 1.0-2.4mm EI 120 U/C & E 120 U/C

PE, ABS or SAN+PVC pipe ≤ Ø32mm with wall thickness 2.0-3.0mm EI 120 U/C & E 120 U/C

PP pipe ≤ Ø 32mm with wall thickness 1.8-4.4mm EI 120 U/C & E 120 U/C

PEX pipe-in-pipe ≤ Ø 25mm EI 120 C/C & E 120 C/C

Reaction to fire (seal only) B-s1,d0  
Sound reduction (seal only) Rw 62 dB  
Pressure with zero leakage Min. 200 Pa



Polyseam Ltd, 15 St Andrews Road,  
Huddersfield, West Yorkshire, HD1 6SB  
Tel: +44 (0) 148 4421036  
Email: post.uk@polyseam.com

As a part of our policy of on-going product development and testing, we reserve the right to modify, alter or change product specifications without giving notice. All information contained in this document is given in good faith and is provided for guidance only. Any drawings provided are for illustrative purposes only. As Polyseam has no control over the methods or competence of installation and of prevailing site conditions, no warranties, expressed or implied, is intended to be given as to the actual performance of the product mentioned or referred to herein and no liability whatsoever will be accepted for any loss, damage or injury arising from the use of the information given.

For all technical details on the products specified please refer to the technical data sheets that can be found on [www.protecta.eu](http://www.protecta.eu)

Signed and approved:

Sheet size: <b>A4</b>	Drawn date & no: 3/1/20
Scale: <b>NTS</b>	Drawn by: K.B

### Installation Instructions

1. Ensure that the surface of the service penetration and surrounding construction is free from all loose contaminants, dust and grease.
2. Install the backing material. Cut this slightly oversize and insert into the gap ensuring a tight friction fit. Ensure correct depth is achieved.
3. Fill the gap or joint with Protecta® FR Acrylic on both sides to the required depth.
4. Apply the sealant generously to prevent air bubbles. Finish the bead with a moist spatula, pallet knife or brush.
5. Place a suitable collar around the pipe and ensure that the collar shell and fixing lugs are positioned tightly to the surface of the floor, so that the fixings can be inserted fully.
6. Where the surface is uneven, apply a sealing bead of Protecta® FR Acrylic between the floor and the collar shell.
7. Attach the collar with screws through all fixing tabs.

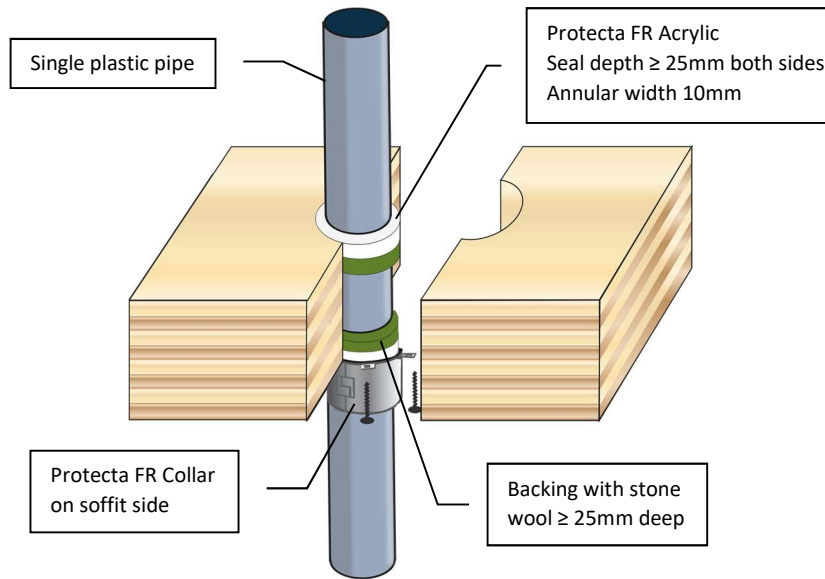

Client:

Job Title:

**Products** Protecta FR Collar  
Protecta FR Acrylic  
Stone wool backing ≥ 33 kg/m<sup>3</sup>  
Wood screws ≥ Ø5 x 100mm

**Application** Fire stopping of plastic pipes in timber floors

**Construction** Minimum floor thickness of 150 mm and comprise solid wood or cross-laminated timber

### Fire, Sound and Air classifications

Fire classifications in tables on the left. For full pipe specifications, please refer to the Installation Instructions; concrete floors.

Reaction to fire (seal only) B-s1,d0

Sound reduction (seal only) Rw 62 dB

Pressure with zero leakage Min. 200 Pa

Services	Min. Collar Height	Classification
≤ Ø50mm PVC-U & PVC-C	30mm	EI 60 C/C, EI 60 U/C, EI 60 C/U, EI 60 U/U (E 90)
≤ Ø90mm PVC-U & PVC-C	50mm	EI 120 C/C, EI 120 U/C, EI 60 C/U, EI 60 U/U
≤ Ø110mm PVC-U & PVC-C	30mm	EI 60 C/C, EI 60 U/C, EI 60 C/U, EI 60 U/U
≤ Ø110mm PVC-U & PVC-C	50mm	EI 120 C/C, EI 90 U/C (E 120), EI 60 C/U
≤ Ø160mm PVC-U & PVC-C	60mm	EI 120 C/C, EI 120 U/C, EI 60 C/U, EI 60 U/U
≤ Ø200mm PVC-U & PVC-C	60mm	EI 60 C/C (E 120)
≤ Ø315mm PVC-U & PVC-C	75mm	EI 60 C/C
≤ Ø400mm PVC-U & PVC-C	100mm	EI 60 C/C
≤ Ø55mm PE, ABS & SAN+PVC	30mm	EI 60 C/C, EI 60 U/C, EI 60 C/U, EI 60 U/U
≤ Ø50mm PE, ABS & SAN+PVC	50mm	EI 120 C/C, EI 120 U/C, EI 60 C/U, EI 60 U/U
≤ Ø110mm PE, ABS & SAN+PVC	30mm	EI 60 C/C, EI 60 U/C
≤ Ø110mm PE, ABS & SAN+PVC	50mm	EI 120 C/C, EI 120 U/C, EI 60 C/U, EI 60 U/U
≤ Ø160mm PE, ABS & SAN+PVC	60mm	EI 120 C/C, EI 120 U/C, EI 60 C/U, EI 60 U/U
≤ Ø200mm PE, ABS & SAN+PVC	60mm	EI 120 C/C
≤ Ø250mm PE, ABS & SAN+PVC	75mm	EI 120 C/C
Ø315x18.7mm PE, ABS & SAN+PVC	75mm	EI 120 C/C
Ø400x36.3mm PE, ABS & SAN+PVC	100mm	EI 90 C/C

Services	Min. Collar Height	Classification
≤ Ø50mm PP	30mm	EI 120 C/C, EI 120 U/C, EI 120 C/U, EI 120 U/U
≤ Ø110mm PP	50mm	EI 120 C/C, EI 120 U/C, EI 60 C/U, EI 60 U/U
≤ Ø140mm PP	60mm	EI 120 C/C, EI 120 U/C, EI 60 C/U, EI 60 U/U
≤ Ø160mm PP	60mm	EI 120 C/C, EI 120 U/C, EI 60 C/U, EI 60 U/U
≤ Ø200mm PP	60mm	EI 120 C/C
≤ Ø250mm PP	75mm	EI 60 C/C
Ø315x28.6mm PP	75mm	EI 60 C/C
≤ Ø400mm PP	100mm	EI 30 C/C



**Protecta**<sup>®</sup>  
Polyseam Ltd, 15 St Andrews Road,  
Huddersfield, West Yorkshire, HD1 6SB  
Tel: +44 (0) 148 4421036  
Email: post.uk@polyseam.com

As a part of our policy of on-going product development and testing, we reserve the right to modify, alter or change product specifications without giving notice. All information contained in this document is given in good faith and is provided for guidance only. Any drawings provided are for illustrative purposes only. As Polyseam has no control over the methods or competence of installation and of prevailing site conditions, no warranties, expressed or implied, is intended to be given as to the actual performance of the product mentioned or referred to herein and no liability whatsoever will be accepted for any loss, damage or injury arising from the use of the information given.

For all technical details on the products specified please refer to the technical data sheets that can be found on [www.protecta.eu](http://www.protecta.eu)

Signed and approved:

Sheet size: <b>A4</b>	Drawn date & no: 3/1/20
Scale: <b>NTS</b>	Drawn by: K.B

Installation Instructions

1. Before installing Protecta® FR Damper ensure that the surface of surrounding construction is free from all loose contaminants, dust and grease.
2. Install the backing material and lock the Damper in position. Cut this slightly oversize and insert into the gap ensuring a tight friction fit. Ensure correct depth is achieved and that the centre point of the Damper is located mid-depth in the floor.
3. Fill the gap or joint with Protecta® FR Acrylic on both sides to the required depth.
4. Apply the sealant generously to prevent air bubbles. Finish the bead with a moist spatula, pallet knife or brush.
5. Connect the ventilation duct(s) to the damper.
6. Insulate the duct towards the fire seal on the top side with stone wool mat.
7. Protecta® FR Acrylic can be over-painted with most emulsion or alkyd (gloss) paints.

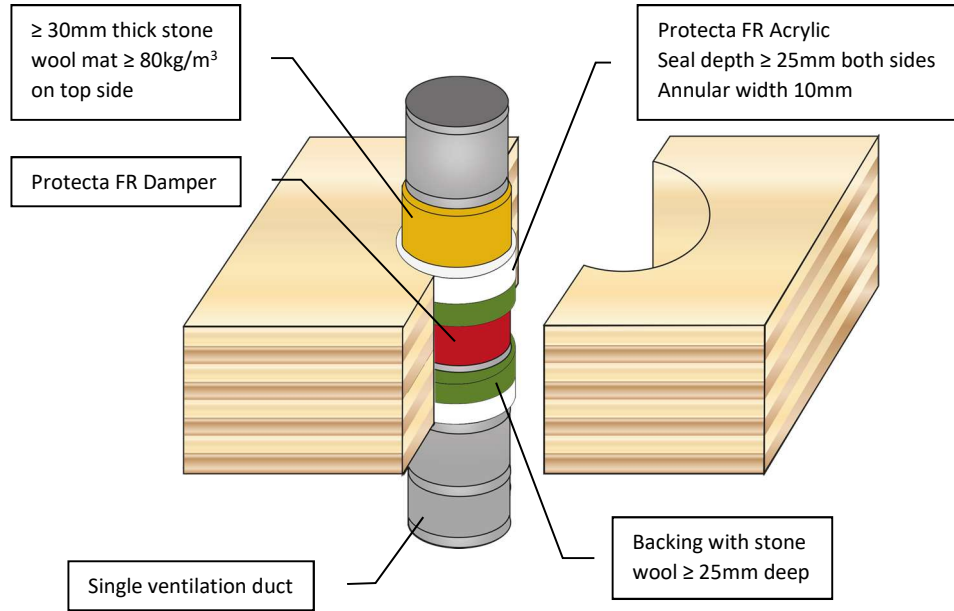

Client:

Job Title:

**Products** Protecta FR Acrylic  
Protecta FR Damper  
Stone wool backing ≥ 33 kg/m<sup>3</sup>

**Application** Fire stopping of ventilation ducts in timber floors

**Construction** Minimum floor thickness of 150 mm and comprise solid wood or cross-laminated timber

**Fire and Sound classifications**

Ventilation duct ≤ Ø400mm with ≥ 150mm stone wool mat EI 90 & E 90

Ventilation duct ≤ Ø1000mm with ≥ 500mm stone wool mat EI 90 & E 90

Sound & Air flow See technical data sheet  
External pressure with zero leakage Min. 200 Pa  
Reaction to fire B-s1,d0



UL-EU-01028-CPR (pending update)

As a part of our policy of on-going product development and testing, we reserve the right to modify, alter or change product specifications without giving notice. All information contained in this document is given in good faith and is provided for guidance only. Any drawings provided are for illustrative purposes only. As Polyseam has no control over the methods or competence of installation and of prevailing site conditions, no warranties, expressed or implied, is intended to be given as to the actual performance of the product mentioned or referred to herein and no liability whatsoever will be accepted for any loss, damage or injury arising from the use of the information given.

For all technical details on the products specified please refer to the technical data sheets that can be found on [www.protecta.eu](http://www.protecta.eu)

Signed and approved:



**Protecta®**  
Polyseam Ltd, 15 St Andrews Road,  
Huddersfield, West Yorkshire, HD1 6SB  
Tel: +44 (0) 148 4421036  
Email: [post.uk@polyseam.com](mailto:post.uk@polyseam.com)

Sheet size: **A4** Drawn date & no: 6/1/20

Scale: **NTS** Drawn by: **K.B**



## Appendix II

-

Blank seals & service penetration solutions in walls

Installation Instructions

1. Before installing Protecta® FR Acrylic ensure that the surface of surrounding construction is free from all loose contaminants, dust and grease.
2. Install the backing material. Cut this slightly oversize and insert into the gap ensuring a tight friction fit. Ensure correct depth is achieved.
3. Fill the gap or joint with Protecta® FR Acrylic on both sides to the required depth.
4. Apply the sealant generously to prevent air bubbles. Finish the bead with a moist spatula, pallet knife or brush.
5. Protecta® FR Acrylic can be over-painted with most emulsion or alkyd (gloss) paints.

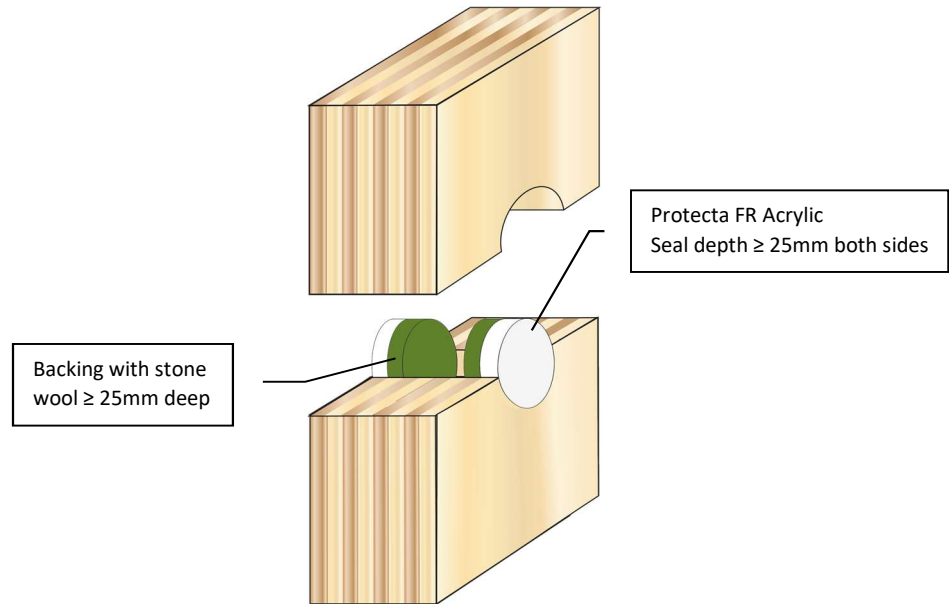

Client:

Job Title:

<b>Products</b>	Protecta FR Acrylic Stone wool backing ≥ 33 kg/m <sup>3</sup>
<b>Application</b>	Fire stopping of blank seals in timber walls
<b>Construction</b>	Minimum wall thickness of 100 mm and comprise solid wood or cross-laminated timber

<b>Fire, Sound and Air classifications</b>	
Blank seal ≤ Ø180mm	EI 120 & E 120
Blank seal ≤ Ø400mm	EI 45 & E 90
Reaction to fire	B-s1,d0
Sound reduction	Rw 62 dB
Pressure with zero leakage	Min. 200 Pa

**Protecta®**  
Polyseam Ltd, 15 St Andrews Road,  
Huddersfield, West Yorkshire, HD1 6SB  
Tel: +44 (0) 148 4421036  
Email: post.uk@polyseam.com



As a part of our policy of on-going product development and testing, we reserve the right to modify, alter or change product specifications without giving notice. All information contained in this document is given in good faith and is provided for guidance only. Any drawings provided are for illustrative purposes only. As Polyseam has no control over the methods or competence of installation and of prevailing site conditions, no warranties, expressed or implied, is intended to be given as to the actual performance of the product mentioned or referred to herein and no liability whatsoever will be accepted for any loss, damage or injury arising from the use of the information given.

For all technical details on the products specified please refer to the technical data sheets that can be found on [www.protecta.eu](http://www.protecta.eu)

Signed and approved:

Sheet size: <b>A4</b>	Drawn date & no: 5/1/20
Scale: <b>NTS</b>	Drawn by: K.B

**Installation Instructions**

1. Before installing Protecta® FR Acrylic ensure that the surface of all service penetrations and surrounding construction is free from all loose contaminants, dust and grease.
2. Install the backing material. Cut this slightly oversize and insert into the gap ensuring a tight friction fit. Ensure correct depth is achieved.
3. Fill the gap or joint with Protecta® FR Acrylic on both sides to the required depth.
4. Apply the sealant generously to prevent air bubbles. Finish the bead with a moist spatula, pallet knife or brush.
5. Protecta® FR Acrylic can be over-painted with most emulsion or alkyd (gloss) paints.

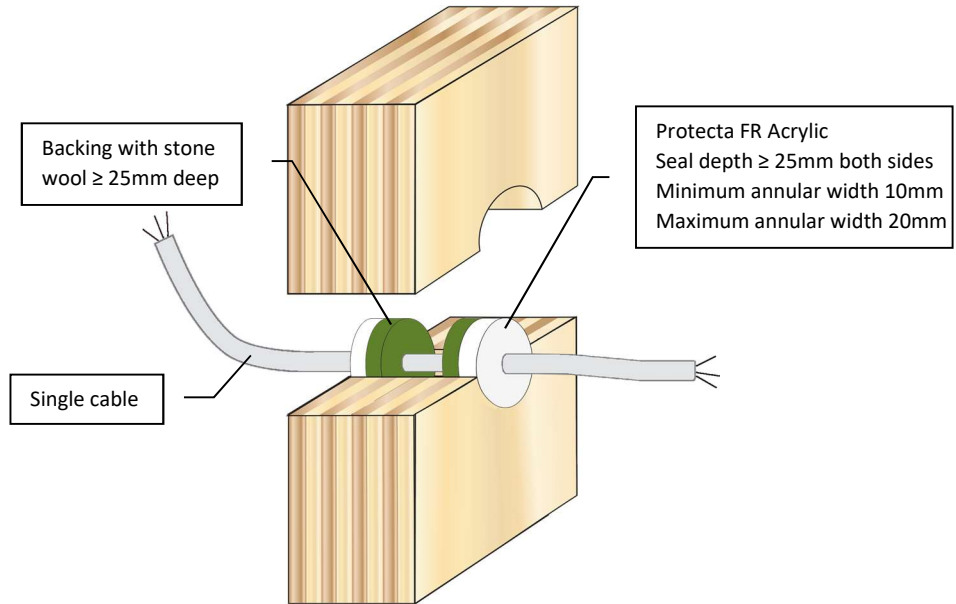

Client:

Job Title:

<b>Products</b>	Protecta FR Acrylic Stone wool backing ≥ 33 kg/m <sup>3</sup>
<b>Application</b>	Fire stopping of cables in timber walls
<b>Construction</b>	Minimum wall thickness of 100 mm and comprise solid wood or cross-laminated timber

<b>Fire, Sound and Air classifications</b>	
Cable ≤ Ø21mm	EI 45 & E 90
Cable ≤ Ø50mm	EI 30 & E 90
Reaction to fire (seal only)	B-s1,d0
Sound reduction (seal only)	Rw 62 dB
Pressure with zero leakage	Min. 200 Pa

**Protecta®**  
Polyseam Ltd, 15 St Andrews Road,  
Huddersfield, West Yorkshire, HD1 6SB  
Tel: +44 (0) 148 4421036  
Email: post.uk@polyseam.com



As a part of our policy of on-going product development and testing, we reserve the right to modify, alter or change product specifications without giving notice. All information contained in this document is given in good faith and is provided for guidance only. Any drawings provided are for illustrative purposes only. As Polyseam has no control over the methods or competence of installation and of prevailing site conditions, no warranties, expressed or implied, is intended to be given as to the actual performance of the product mentioned or referred to herein and no liability whatsoever will be accepted for any loss, damage or injury arising from the use of the information given.

For all technical details on the products specified please refer to the technical data sheets that can be found on [www.protecta.eu](http://www.protecta.eu)

Signed and approved:

Sheet size:	Drawn date & no:
<b>A4</b>	5/1/20
Scale:	Drawn by:
<b>NTS</b>	K.B

**Installation Instructions**

1. Before installing Protecta® FR Acrylic ensure that the surface of all service penetrations and surrounding construction is free from all loose contaminants, dust and grease.
2. Install the backing material. Cut this slightly oversize and insert into the gap ensuring a tight friction fit. Ensure correct depth is achieved.
3. Fill the gap or joint with Protecta® FR Acrylic on both sides to the required depth.
4. Apply the sealant generously to prevent air bubbles. Finish the bead with a moist spatula, pallet knife or brush.
5. Coat the cable on both sides with Protecta® Service Coat FR-1 to the required length and thickness.
6. Protecta® FR Acrylic can be over-painted with most emulsion or alkyd (gloss) paints.

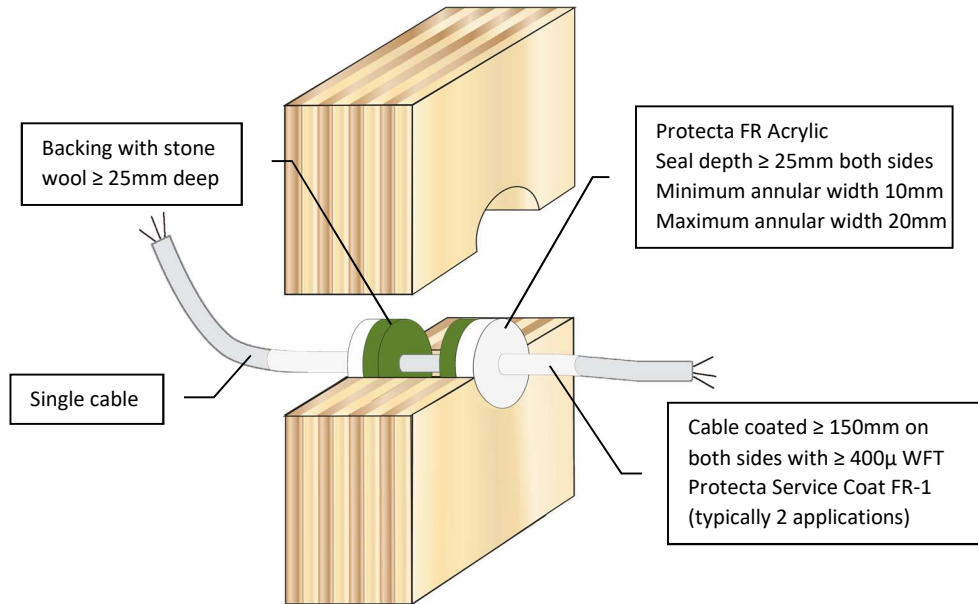

Client:

Job Title:

<b>Products</b>	Protecta FR Acrylic Protecta Service Coat FR-1 Stone wool backing ≥ 33 kg/m <sup>3</sup>
<b>Application</b>	Fire stopping of cables in timber walls
<b>Construction</b>	Minimum wall thickness of 100 mm and comprise solid wood or cross-laminated timber

<b>Fire, Sound and Air classifications</b>	
Cable ≤ Ø21mm	EI 90 & E 90
Reaction to fire (seal only)	B-s1,d0
Sound reduction (seal only)	Rw 62 dB
Pressure with zero leakage	Min. 200 Pa

**Protecta®**  
Polyseam Ltd, 15 St Andrews Road,  
Huddersfield, West Yorkshire, HD1 6SB  
Tel: +44 (0) 148 4421036  
Email: post.uk@polyseam.com



As a part of our policy of on-going product development and testing, we reserve the right to modify, alter or change product specifications without giving notice. All information contained in this document is given in good faith and is provided for guidance only. Any drawings provided are for illustrative purposes only. As Polyseam has no control over the methods or competence of installation and of prevailing site conditions, no warranties, expressed or implied, is intended to be given as to the actual performance of the product mentioned or referred to herein and no liability whatsoever will be accepted for any loss, damage or injury arising from the use of the information given.

For all technical details on the products specified please refer to the technical data sheets that can be found on [www.protecta.eu](http://www.protecta.eu)

Signed and approved:

Sheet size: <b>A4</b>	Drawn date & no: 5/1/20
Scale: <b>NTS</b>	Drawn by: K.B

**Installation Instructions**

1. Before installing Protecta® FR Acrylic ensure that the surface of all service penetrations and surrounding construction is free from all loose contaminants, dust and grease.
2. Install the backing material. Cut this slightly oversize and insert into the gap ensuring a tight friction fit. Ensure correct depth is achieved.
3. Fill the gap or joint with Protecta® FR Acrylic on both sides to the required depth.
4. Apply the sealant generously to prevent air bubbles. Finish the bead with a moist spatula, pallet knife or brush.
5. Protecta® FR Acrylic can be over-painted with most emulsion or alkyd (gloss) paints.

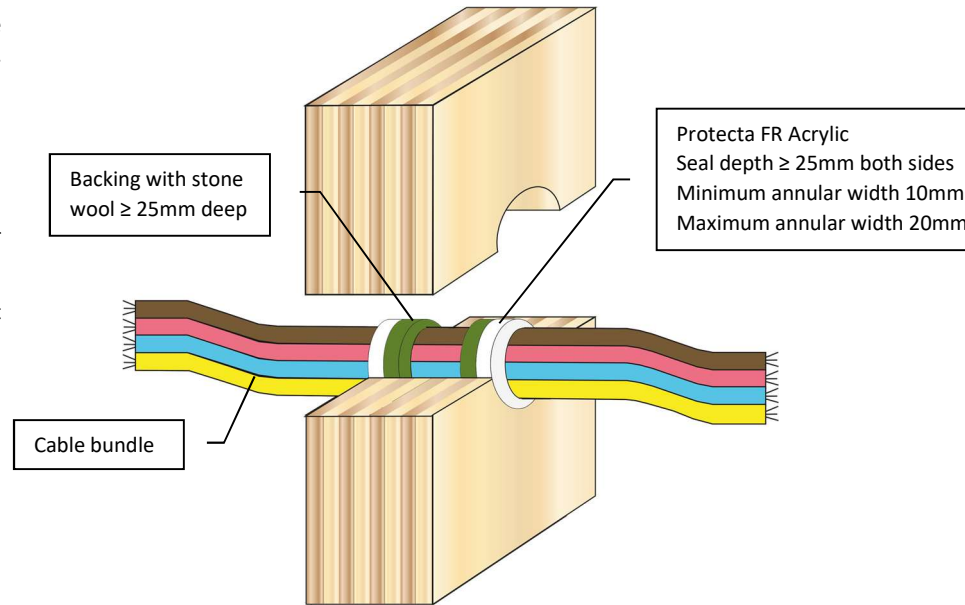

Client:

Job Title:

**Products** Protecta FR Acrylic  
Stone wool backing ≥ 33 kg/m<sup>3</sup>

**Application** Fire stopping of cables in timber walls

**Construction** Minimum wall thickness of 100 mm and comprise solid wood or cross-laminated timber

**Fire, Sound and Air classifications**

Cables ≤ Ø21mm in a bundle ≤ Ø100mm	EI 45 & E 90
Cables ≤ Ø50mm in a bundle ≤ Ø100mm	EI 30 & E 90
Reaction to fire (seal only)	B-s1,d0
Sound reduction (seal only)	Rw 62 dB
Pressure with zero leakage	Min. 200 Pa

**Protecta**<sup>®</sup>  
Polyseam Ltd, 15 St Andrews Road,  
Huddersfield, West Yorkshire, HD1 6SB  
Tel: +44 (0) 148 4421036  
Email: post.uk@polyseam.com



As a part of our policy of on-going product development and testing, we reserve the right to modify, alter or change product specifications without giving notice. All information contained in this document is given in good faith and is provided for guidance only. Any drawings provided are for illustrative purposes only. As Polyseam has no control over the methods or competence of installation and of prevailing site conditions, no warranties, expressed or implied, is intended to be given as to the actual performance of the product mentioned or referred to herein and no liability whatsoever will be accepted for any loss, damage or injury arising from the use of the information given.

For all technical details on the products specified please refer to the technical data sheets that can be found on [www.protecta.eu](http://www.protecta.eu)

Signed and approved:

Sheet size: **A4**      Drawn date & no: 5/1/20

Scale: **NTS**      Drawn by: **K.B**

**Installation Instructions**

1. Before installing Protecta® FR Acrylic ensure that the surface of all service penetrations and surrounding construction is free from all loose contaminants, dust and grease.
2. Install the backing material. Cut this slightly oversize and insert into the gap ensuring a tight friction fit. Ensure correct depth is achieved.
3. Fill the gap or joint with Protecta® FR Acrylic on both sides to the required depth.
4. Apply the sealant generously to prevent air bubbles. Finish the bead with a moist spatula, pallet knife or brush.
5. Coat the cable bundle on both sides with Protecta® Service Coat FR-1 to the required length and thickness.
6. Protecta® FR Acrylic can be over-painted with most emulsion or alkyd (gloss) paints.

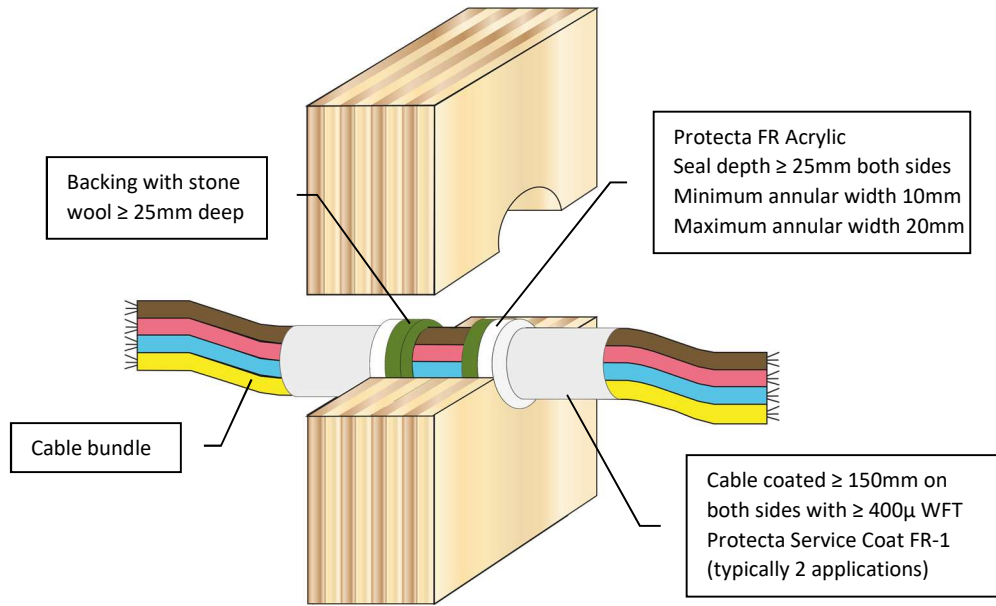

Client:

Job Title:

<b>Products</b>	Protecta FR Acrylic Protecta Service Coat FR-1 Stone wool backing ≥ 33 kg/m <sup>3</sup>
<b>Application</b>	Fire stopping of cables in timber walls
<b>Construction</b>	Minimum wall thickness of 100 mm and comprise solid wood or cross-laminated timber

<b>Fire, Sound and Air classifications</b>	
Cables ≤ Ø21mm in a bundle ≤ Ø100mm	EI 60 & E 90
Reaction to fire (seal only)	B-s1,d0
Sound reduction (seal only)	Rw 62 dB
Pressure with zero leakage	Min. 200 Pa

**Protecta®**  
Polyseam Ltd, 15 St Andrews Road,  
Huddersfield, West Yorkshire, HD1 6SB  
Tel: +44 (0) 148 4421036  
Email: post.uk@polyseam.com



As a part of our policy of on-going product development and testing, we reserve the right to modify, alter or change product specifications without giving notice. All information contained in this document is given in good faith and is provided for guidance only. Any drawings provided are for illustrative purposes only. As Polyseam has no control over the methods or competence of installation and of prevailing site conditions, no warranties, expressed or implied, is intended to be given as to the actual performance of the product mentioned or referred to herein and no liability whatsoever will be accepted for any loss, damage or injury arising from the use of the information given.

For all technical details on the products specified please refer to the technical data sheets that can be found on [www.protecta.eu](http://www.protecta.eu)

Signed and approved:

Sheet size: <b>A4</b>	Drawn date & no: 5/1/20
Scale: <b>NTS</b>	Drawn by: K.B

Installation Instructions

1. Before installing Protecta® FR Service Transit ensure that the surface of all service penetrations and surrounding construction is free from all loose contaminants, dust and grease.
2. Install the backing material and lock the Service Transit in position. Cut this slightly oversize and insert into the gap ensuring a tight friction fit. Ensure correct depth is achieved and that the centre point of the transit is located mid-depth in the floor.
3. Fill the gap or joint with Protecta® FR Acrylic on both sides to the required depth.
4. Apply the sealant generously to prevent air bubbles. Finish the bead with a moist spatula, pallet knife or brush.
5. Before cables and/or plastic pipes are inserted through the Service Transit, remove the fibre plug from the middle of the Service Transit. After the insertion of services is completed, ensure that the fibre plug is refitted and positioned correctly around the services in the middle of the Service Transit, leaving no openings so a cold smoke barrier is achieved.
6. Make sure labels with retrofit instructions are placed near the Service Transit on both sides after installation, so future service installations are completed correctly by reinstating the fibre plug.
7. Protecta® FR Acrylic can be over-painted with most emulsion or alkyd (gloss) paints.

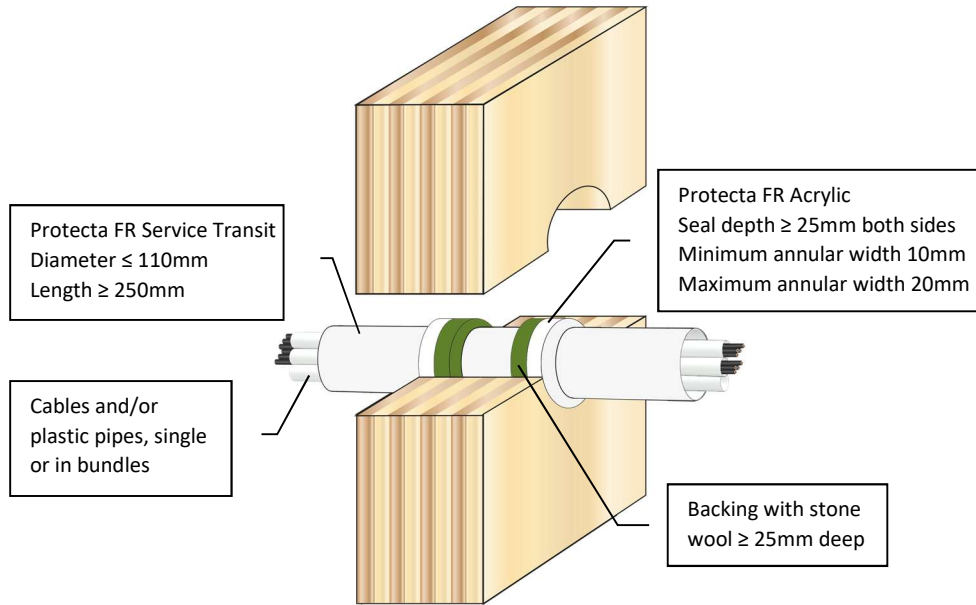

Client:

Job Title:

<b>Products</b>	Protecta FR Acrylic Protecta FR Service Transit Stone wool backing ≥ 33 kg/m <sup>3</sup>
<b>Application</b>	Fire stopping of cables and plastic pipes in timber walls
<b>Construction</b>	Minimum wall thickness of 100 mm and comprise solid wood or cross-laminated timber

<b>Fire and Sound classifications</b>	
Empty, or with cables ≤ Ø21mm	EI 90 & E 90
Cables ≤ Ø80mm	EI 60 & E 90
Plastic pipes ≤ Ø32mm, empty or with penetrating cables ≤ Ø21mm, single or in bundles	EI 90 U/C & E 90 U/C
Sound reduction	Rw 42 dB

**Protecta®**  
Polyseam Ltd, 15 St Andrews Road,  
Huddersfield, West Yorkshire, HD1 6SB  
Tel: +44 (0) 148 4421036  
Email: post.uk@polyseam.com



As a part of our policy of on-going product development and testing, we reserve the right to modify, alter or change product specifications without giving notice. All information contained in this document is given in good faith and is provided for guidance only. Any drawings provided are for illustrative purposes only. As Polyseam has no control over the methods or competence of installation and of prevailing site conditions, no warranties, expressed or implied, is intended to be given as to the actual performance of the product mentioned or referred to herein and no liability whatsoever will be accepted for any loss, damage or injury arising from the use of the information given.

For all technical details on the products specified please refer to the technical data sheets that can be found on [www.protecta.eu](http://www.protecta.eu)

Signed and approved:

Sheet size: <b>A4</b>	Drawn date & no: 5/1/20
Scale: <b>NTS</b>	Drawn by: K.B

Installation Instructions

1. Before installing Protecta® FR Acrylic ensure that the surface of all service penetrations and surrounding construction is free from all loose contaminants, dust and grease.
2. As Protecta® FR Acrylic is water based, in cases where corrosion protection is a problem; some metals may require a barrier between the sealant and the metal surface prior to this installation.
3. Install the backing material. Cut this slightly oversize and insert into the gap ensuring a tight friction fit. Ensure correct depth is achieved.
4. Fill the gap or joint with Protecta® FR Acrylic on both sides to the required depth.
5. Apply the sealant generously to prevent air bubbles. Finish the bead with a moist spatula, pallet knife or brush.
6. Protecta® FR Acrylic can be over-painted with most emulsion or alkyd (gloss) paints.

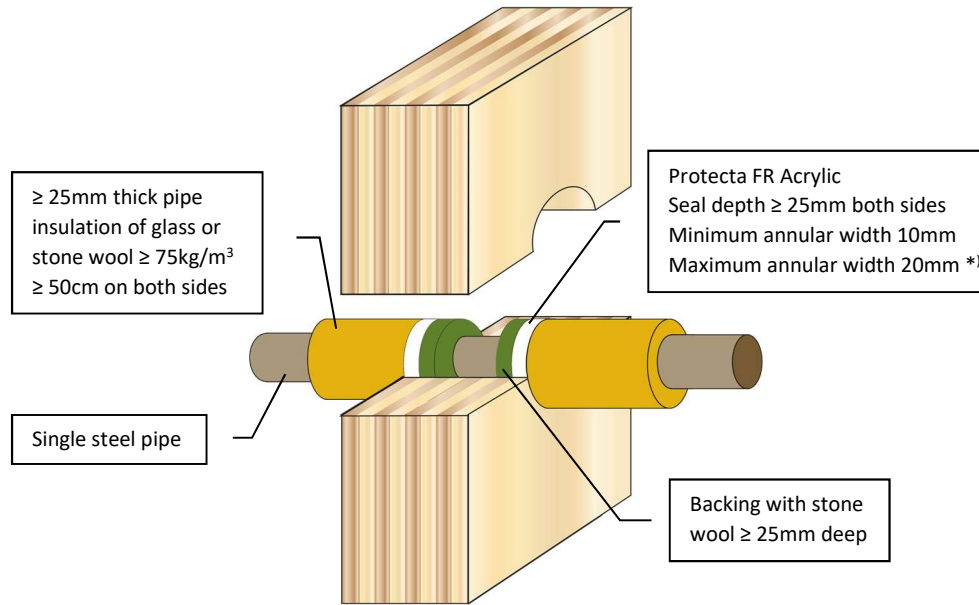

\*) For pipes above Ø140mm, the annular width should be 10mm



As a part of our policy of on-going product development and testing, we reserve the right to modify, alter or change product specifications without giving notice. All information contained in this document is given in good faith and is provided for guidance only. Any drawings provided are for illustrative purposes only. As Polyseam has no control over the methods or competence of installation and of prevailing site conditions, no warranties, expressed or implied, is intended to be given as to the actual performance of the product mentioned or referred to herein and no liability whatsoever will be accepted for any loss, damage or injury arising from the use of the information given.

For all technical details on the products specified please refer to the technical data sheets that can be found on [www.protecta.eu](http://www.protecta.eu)

Signed and approved:

Client:	
Job Title:	
<b>Products</b>	Protecta FR Acrylic Stone wool backing ≥ 33 kg/m <sup>3</sup>
<b>Application</b>	Fire stopping of steel pipes in timber walls
<b>Construction</b>	Minimum wall thickness of 100 mm and comprise solid wood or cross-laminated timber
<b>Fire, Sound and Air classifications</b>	
Steel pipe ≤ Ø273mm	EI 60 C/U & E 90 C/U
Reaction to fire (seal only)	B-s1,d0
Sound reduction (seal only)	Rw 62 dB
Pressure with zero leakage	Min. 200 Pa
	
Polyseam Ltd, 15 St Andrews Road, Huddersfield, West Yorkshire, HD1 6SB Tel: +44 (0) 148 4421036 Email: <a href="mailto:post.uk@polyseam.com">post.uk@polyseam.com</a>	
Sheet size: <b>A4</b>	Drawn date & no: 5/1/20
Scale: <b>NTS</b>	Drawn by: K.B



Installation Instructions

1. Before installing Protecta® FR Graphite ensure that the surface of all service penetrations and surrounding construction is free from all loose contaminants, dust and grease.
2. Install the backing material. Cut this slightly oversize and insert into the gap ensuring a tight friction fit. Ensure correct depth is achieved.
3. Fill the gap or joint with Protecta® FR Graphite on both sides to the required depth.
4. Apply the sealant generously avoiding air bubbles. Finish the bead with a moist spatula or pallet knife. Avoid excessive tooling/smoothing as this may make the seal surface wet and soft.
5. Protecta® FR Graphite can be over-painted with most emulsion or alkyd (gloss) paints.

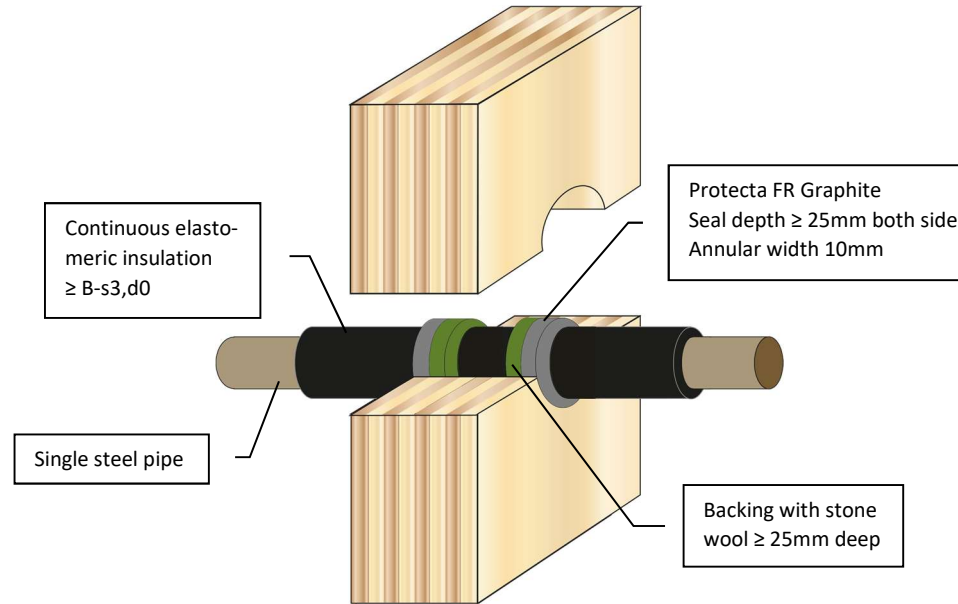

Client:

Job Title:

<b>Products</b>	Protecta FR Graphite Stone wool backing ≥ 33 kg/m <sup>3</sup>
<b>Application</b>	Fire stopping of steel pipes in timber walls
<b>Construction</b>	Minimum wall thickness of 100 mm and comprise solid wood or cross-laminated timber

<b>Fire and Sound classifications</b>	
Steel pipe ≤ Ø114mm with 13mm thick pipe insulation	EI 90 C/U & E 90 C/U
Steel pipe ≤ Ø114mm with 19 – 25mm thick pipe insulation	EI 45 C/U & E 90 C/U
Reaction to fire (seal only)	B-s1,d0
Sound reduction (seal only)	Rw 53 dB



Polyseam Ltd, 15 St Andrews Road,  
Huddersfield, West Yorkshire, HD1 6SB  
Tel: +44 (0) 148 4421036  
Email: [post.uk@polyseam.com](mailto:post.uk@polyseam.com)

As a part of our policy of on-going product development and testing, we reserve the right to modify, alter or change product specifications without giving notice. All information contained in this document is given in good faith and is provided for guidance only. Any drawings provided are for illustrative purposes only. As Polyseam has no control over the methods or competence of installation and of prevailing site conditions, no warranties, expressed or implied, is intended to be given as to the actual performance of the product mentioned or referred to herein and no liability whatsoever will be accepted for any loss, damage or injury arising from the use of the information given.

For all technical details on the products specified please refer to the technical data sheets that can be found on [www.protecta.eu](http://www.protecta.eu)

Signed and approved:

Sheet size: <b>A4</b>	Drawn date & no: 5/1/20
Scale: <b>NTS</b>	Drawn by: K.B

Installation Instructions

1. Before installing Protecta® FR Acrylic ensure that the surface of all service penetrations and surrounding construction is free from all loose contaminants, dust and grease.
2. As Protecta® FR Acrylic is water based, in cases where corrosion protection is a problem; some metals may require a barrier between the sealant and the metal surface prior to this installation.
3. Install the backing material. Cut this slightly oversize and insert into the gap ensuring a tight friction fit. Ensure correct depth is achieved.
4. Fill the gap or joint with Protecta® FR Acrylic on both sides to the required depth.
5. Apply the sealant generously to prevent air bubbles. Finish the bead with a moist spatula, pallet knife or brush.
6. Protecta® FR Acrylic can be over-painted with most emulsion or alkyd (gloss) paints.

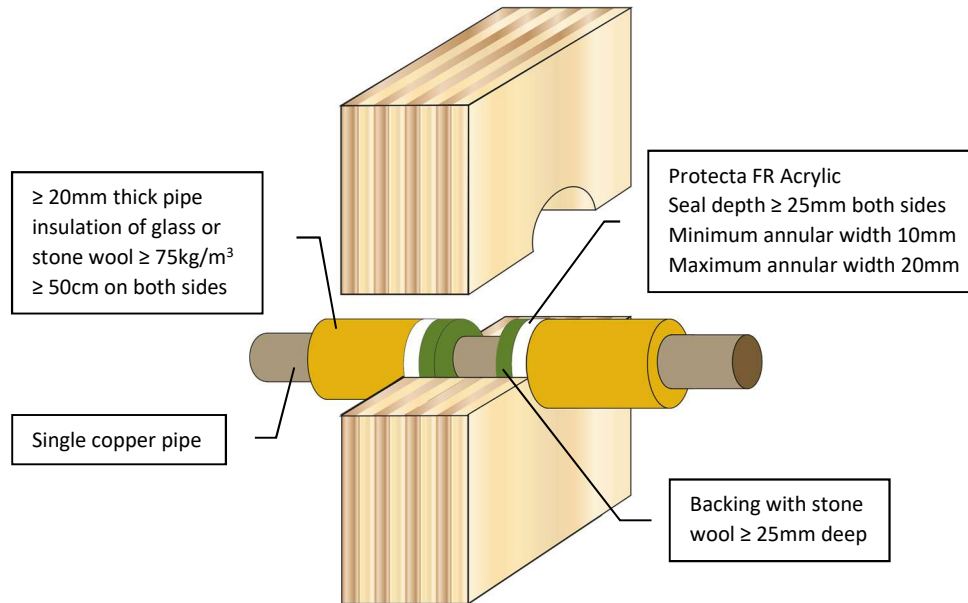

Client:

Job Title:

<b>Products</b>	Protecta FR Acrylic Stone wool backing ≥ 33 kg/m <sup>3</sup>
<b>Application</b>	Fire stopping of copper pipes in timber walls
<b>Construction</b>	Minimum wall thickness of 100 mm and comprise solid wood or cross-laminated timber

<b>Fire, Sound and Air classifications</b>	
Copper pipe ≤ Ø54mm	EI 60 C/C & E 90 C/C
Reaction to fire (seal only)	B-s1,d0
Sound reduction (seal only)	Rw 62 dB
Pressure with zero leakage	Min. 200 Pa

**Protecta**<sup>®</sup>  
 Polyseam Ltd, 15 St Andrews Road,  
 Huddersfield, West Yorkshire, HD1 6SB  
 Tel: +44 (0) 148 4421036  
 Email: post.uk@polyseam.com



As a part of our policy of on-going product development and testing, we reserve the right to modify, alter or change product specifications without giving notice. All information contained in this document is given in good faith and is provided for guidance only. Any drawings provided are for illustrative purposes only. As Polyseam has no control over the methods or competence of installation and of prevailing site conditions, no warranties, expressed or implied, is intended to be given as to the actual performance of the product mentioned or referred to herein and no liability whatsoever will be accepted for any loss, damage or injury arising from the use of the information given.

For all technical details on the products specified please refer to the technical data sheets that can be found on [www.protecta.eu](http://www.protecta.eu)

Signed and approved:

Sheet size: <b>A4</b>	Drawn date & no: 5/1/20
Scale: <b>NTS</b>	Drawn by: K.B

Installation Instructions

1. Before installing Protecta® FR Graphite ensure that the surface of all service penetrations and surrounding construction is free from all loose contaminants, dust and grease.
2. Install the backing material. Cut this slightly oversize and insert into the gap ensuring a tight friction fit. Ensure correct depth is achieved.
3. Fill the gap or joint with Protecta® FR Graphite on both sides to the required depth.
4. Apply the sealant generously avoiding air bubbles. Finish the bead with a moist spatula or pallet knife. Avoid excessive tooling/smoothing as this may make the seal surface wet and soft.
5. Protecta® FR Graphite can be over-painted with most emulsion or alkyd (gloss) paints.

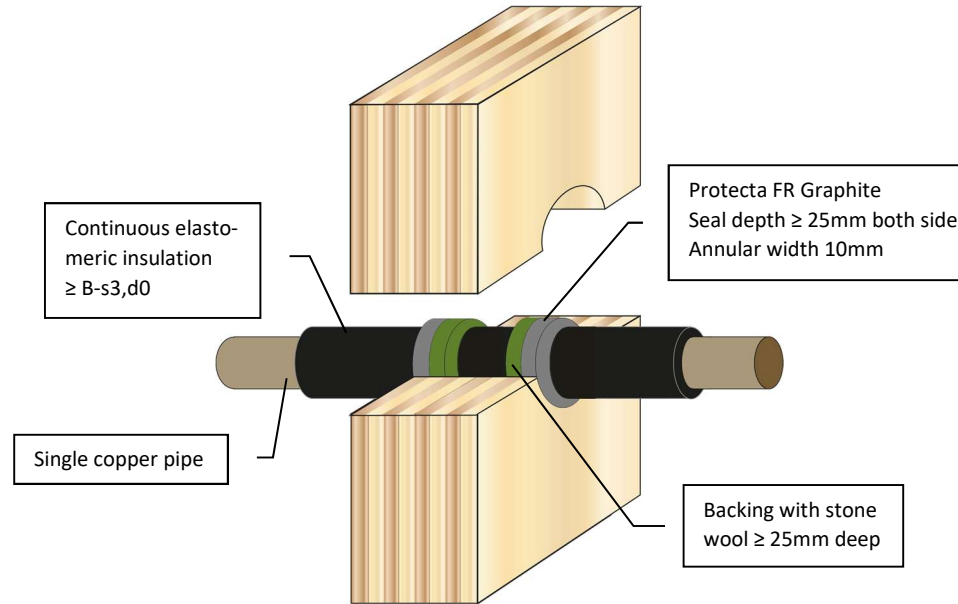

Client:

Job Title:

<b>Products</b>	Protecta FR Graphite Stone wool backing ≥ 33 kg/m <sup>3</sup>
<b>Application</b>	Fire stopping of copper pipes in timber walls
<b>Construction</b>	Minimum wall thickness of 100 mm and comprise solid wood or cross-laminated timber

<b>Fire and Sound classifications</b>	
Copper pipe ≤ Ø12mm with 13mm thick pipe insulation	EI 120 C/C & E 120 C/C
Copper pipe ≤ Ø54mm with 13mm thick pipe insulation	EI 90 C/C & E 120 C/C
Copper pipe ≤ Ø54mm with 19 – 25mm thick pipe insulation	EI 30 C/C & E 120 C/C
Reaction to fire (seal only)	B-s1,d0
Sound reduction (seal only)	Rw 53 dB



Polyseam Ltd, 15 St Andrews Road,  
Huddersfield, West Yorkshire, HD1 6SB  
Tel: +44 (0) 148 4421036  
Email: [post.uk@polyseam.com](mailto:post.uk@polyseam.com)

As a part of our policy of on-going product development and testing, we reserve the right to modify, alter or change product specifications without giving notice. All information contained in this document is given in good faith and is provided for guidance only. Any drawings provided are for illustrative purposes only. As Polyseam has no control over the methods or competence of installation and of prevailing site conditions, no warranties, expressed or implied, is intended to be given as to the actual performance of the product mentioned or referred to herein and no liability whatsoever will be accepted for any loss, damage or injury arising from the use of the information given.

For all technical details on the products specified please refer to the technical data sheets that can be found on [www.protecta.eu](http://www.protecta.eu)

Signed and approved:

Sheet size: <b>A4</b>	Drawn date & no: 5/1/20
Scale: <b>NTS</b>	Drawn by: K.B

Installation Instructions

1. Before installing Protecta® FR Acrylic ensure that the surface of all service penetrations and surrounding construction is free from all loose contaminants, dust and grease.
2. Install the backing material. Cut this slightly oversize and insert into the gap ensuring a tight friction fit. Ensure correct depth is achieved.
3. Fill the gap or joint with Protecta® FR Acrylic on both sides to the required depth.
4. Apply the sealant generously to prevent air bubbles. Finish the bead with a moist spatula, pallet knife or brush.
5. Protecta® FR Acrylic can be over-painted with most emulsion or alkyd (gloss) paints.

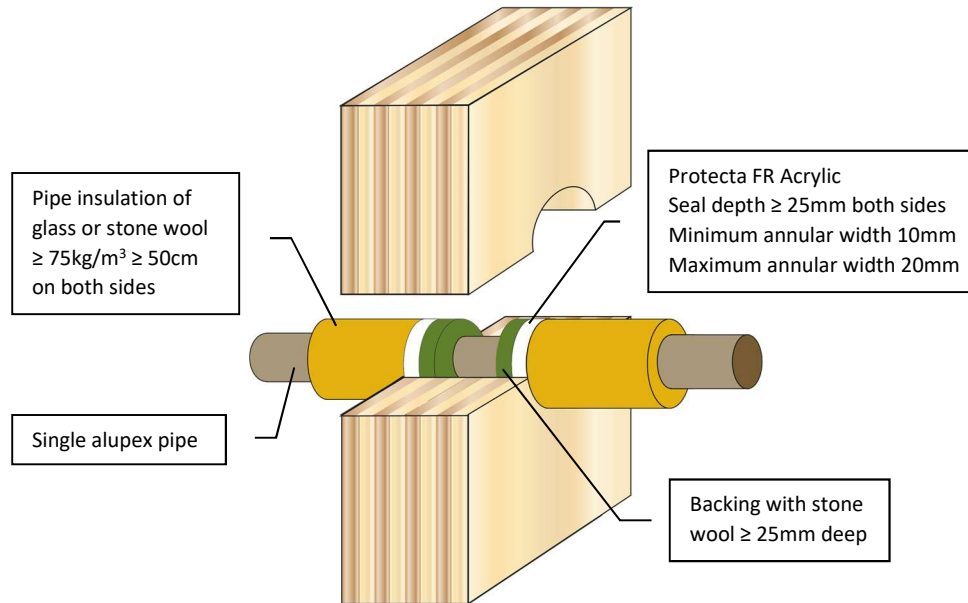

Client:

Job Title:

<b>Products</b>	Protecta FR Acrylic Stone wool backing ≥ 33 kg/m <sup>3</sup>
<b>Application</b>	Fire stopping of alupex pipes in timber walls
<b>Construction</b>	Minimum wall thickness of 100 mm and comprise solid wood or cross-laminated timber

<b>Fire, Sound and Air classifications</b>	
Alupex pipe ≤ Ø16mm with ≥ 20mm thick pipe insulation	EI 90 C/C & E 90 C/C
Alupex pipe ≤ Ø75mm with ≥ 25mm thick pipe insulation	EI 90 C/C & E 90 C/C
Reaction to fire (seal only)	B-s1,d0
Sound reduction (seal only)	Rw 62 dB
Pressure with zero leakage	Min. 200 Pa

**Protecta®**  
Polyseam Ltd, 15 St Andrews Road,  
Huddersfield, West Yorkshire, HD1 6SB  
Tel: +44 (0) 148 4421036  
Email: post.uk@polyseam.com



As a part of our policy of on-going product development and testing, we reserve the right to modify, alter or change product specifications without giving notice. All information contained in this document is given in good faith and is provided for guidance only. Any drawings provided are for illustrative purposes only. As Polyseam has no control over the methods or competence of installation and of prevailing site conditions, no warranties, expressed or implied, is intended to be given as to the actual performance of the product mentioned or referred to herein and no liability whatsoever will be accepted for any loss, damage or injury arising from the use of the information given.

For all technical details on the products specified please refer to the technical data sheets that can be found on [www.protecta.eu](http://www.protecta.eu)

Signed and approved:

Sheet size:	Drawn date & no:
<b>A4</b>	5/1/20
Scale:	Drawn by:
<b>NTS</b>	K.B

Installation Instructions

1. Before installing Protecta® FR Graphite ensure that the surface of all service penetrations and surrounding construction is free from all loose contaminants, dust and grease.
2. Install the backing material. Cut this slightly oversize and insert into the gap ensuring a tight friction fit. Ensure correct depth is achieved.
3. Fill the gap or joint with Protecta® FR Graphite on both sides to the required depth.
4. Apply the sealant generously avoiding air bubbles. Finish the bead with a moist spatula or pallet knife. Avoid excessive tooling/smoothing as this may make the seal surface wet and soft.
5. Protecta® FR Graphite can be over-painted with most emulsion or alkyd (gloss) paints.

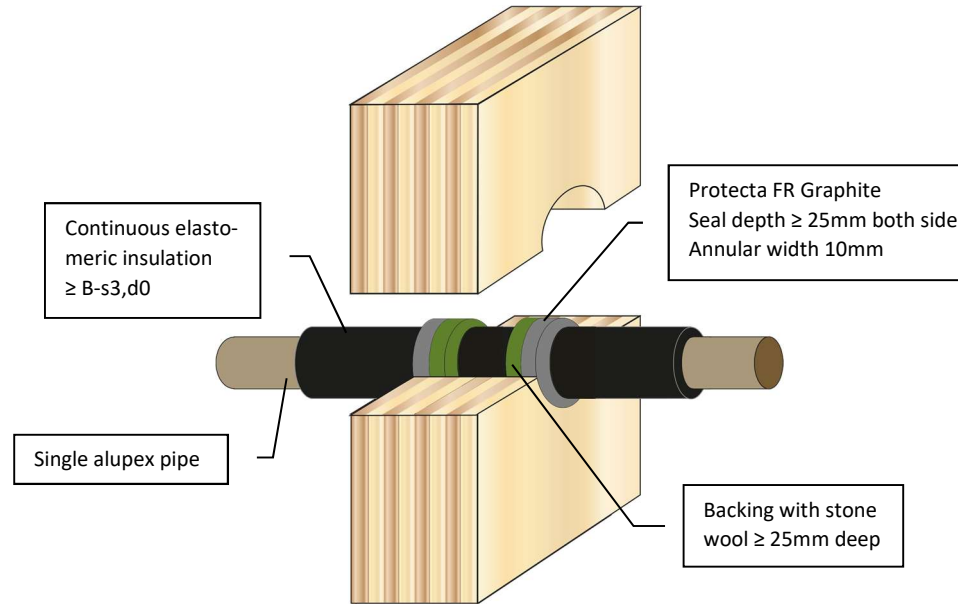

Client:

Job Title:

<b>Products</b>	Protecta FR Graphite Stone wool backing ≥ 33 kg/m <sup>3</sup>
<b>Application</b>	Fire stopping of alupex pipes in timber walls
<b>Construction</b>	Minimum wall thickness of 100 mm and comprise solid wood or cross-laminated timber

<b>Fire and Sound classifications</b>	
Alupex pipe ≤ Ø16mm with 13mm thick pipe insulation	EI 120 C/C & E 120 C/C
Alupex pipe ≤ Ø75mm with 13 – 19mm thick pipe insulation	EI 45 C/C & E 90 C/C
Alupex pipe ≤ Ø75mm with 25mm thick pipe insulation	EI 90 C/C & E 90 C/C
Reaction to fire (seal only)	B-s1,d0
Sound reduction (seal only)	Rw 53 dB



**Protecta®**  
Polyseam Ltd, 15 St Andrews Road,  
Huddersfield, West Yorkshire, HD1 6SB  
Tel: +44 (0) 148 4421036  
Email: post.uk@polyseam.com

As a part of our policy of on-going product development and testing, we reserve the right to modify, alter or change product specifications without giving notice. All information contained in this document is given in good faith and is provided for guidance only. Any drawings provided are for illustrative purposes only. As Polyseam has no control over the methods or competence of installation and of prevailing site conditions, no warranties, expressed or implied, is intended to be given as to the actual performance of the product mentioned or referred to herein and no liability whatsoever will be accepted for any loss, damage or injury arising from the use of the information given.

For all technical details on the products specified please refer to the technical data sheets that can be found on [www.protecta.eu](http://www.protecta.eu)

Signed and approved:

Sheet size: <b>A4</b>	Drawn date & no: 5/1/20
Scale: <b>NTS</b>	Drawn by: K.B

Installation Instructions

1. Before installing Protecta® FR Acrylic ensure that the surface of all service penetrations and surrounding construction is free from all loose contaminants, dust and grease.
2. Install the backing material. Cut this slightly oversize and insert into the gap ensuring a tight friction fit. Ensure correct depth is achieved.
3. Fill the gap or joint with Protecta® FR Acrylic on both sides to the required depth.
4. Apply the sealant generously to prevent air bubbles. Finish the bead with a moist spatula, pallet knife or brush.
5. Protecta® FR Acrylic can be over-painted with most emulsion or alkyd (gloss) paints.

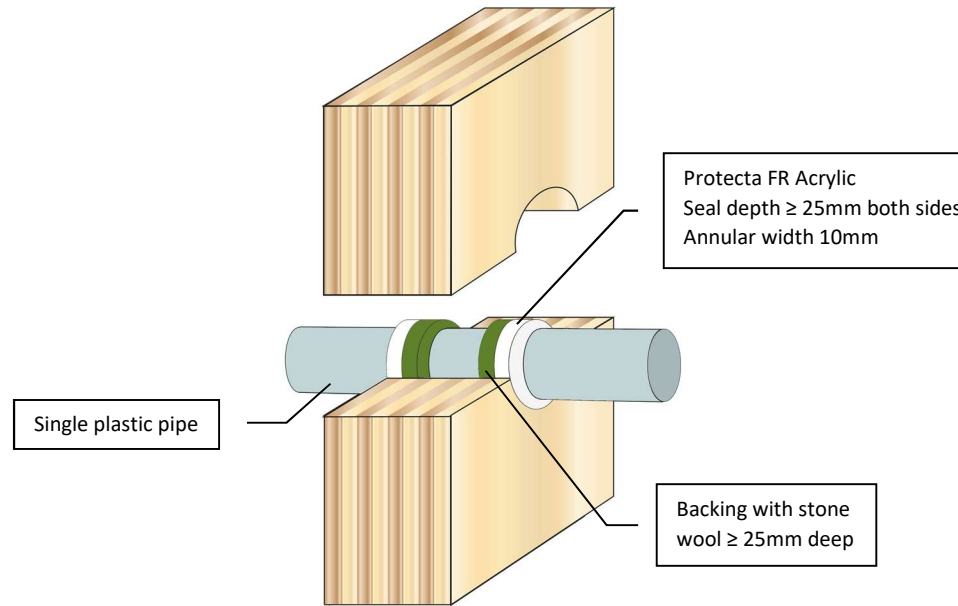

Client:

Job Title:

**Products** Protecta FR Acrylic  
Stone wool backing ≥ 33 kg/m<sup>3</sup>  
**Application** Fire stopping of plastic pipes in timber walls  
**Construction** Minimum wall thickness of 100 mm and comprise solid wood or cross-laminated timber

**Fire, Sound and Air classifications**

PVC-U or PVC-C pipe ≤ Ø32mm with wall thickness 1.0-2.4mm EI 90 U/C & E 90 U/C

PE, ABS or SAN+PVC pipe ≤ Ø32mm with wall thickness 2.0-3.0mm EI 90 U/C & E 90 U/C

PP pipe ≤ Ø 32mm with wall thickness 1.8-4.4mm EI 90 U/C & E 90 U/C

PEX pipe-in-pipe ≤ Ø 25mm EI 90 C/C & E 90 C/C

Reaction to fire (seal only) B-s1,d0  
Sound reduction (seal only) Rw 62 dB  
Pressure with zero leakage Min. 200 Pa



**Protecta®**  
Polyseam Ltd, 15 St Andrews Road,  
Huddersfield, West Yorkshire, HD1 6SB  
Tel: +44 (0) 148 4421036  
Email: post.uk@polyseam.com

As a part of our policy of on-going product development and testing, we reserve the right to modify, alter or change product specifications without giving notice. All information contained in this document is given in good faith and is provided for guidance only. Any drawings provided are for illustrative purposes only. As Polyseam has no control over the methods or competence of installation and of prevailing site conditions, no warranties, expressed or implied, is intended to be given as to the actual performance of the product mentioned or referred to herein and no liability whatsoever will be accepted for any loss, damage or injury arising from the use of the information given.

For all technical details on the products specified please refer to the technical data sheets that can be found on [www.protecta.eu](http://www.protecta.eu)

Signed and approved:

Sheet size: **A4** Drawn date & no: 5/1/20

Scale: **NTS** Drawn by: **K.B**

**Installation Instructions**

1. Ensure that the surface of the service penetration and surrounding construction is free from all loose contaminants, dust and grease.
2. Install the backing material. Cut this slightly oversize and insert into the gap ensuring a tight friction fit. Ensure correct depth is achieved.
3. Fill the gap or joint with Protecta® FR Acrylic on both sides to the required depth.
4. Apply the sealant generously to prevent air bubbles. Finish the bead with a moist spatula, pallet knife or brush.
5. Place suitable collars around the pipe and ensure that the collar shells and fixing lugs are positioned tightly to the surface of the wall, so that the fixings can be inserted fully.
6. Where the surface is uneven, apply a sealing bead of Protecta® FR Acrylic between the wall and the collar shell.
7. Attach the collar with screws through all fixing tabs.

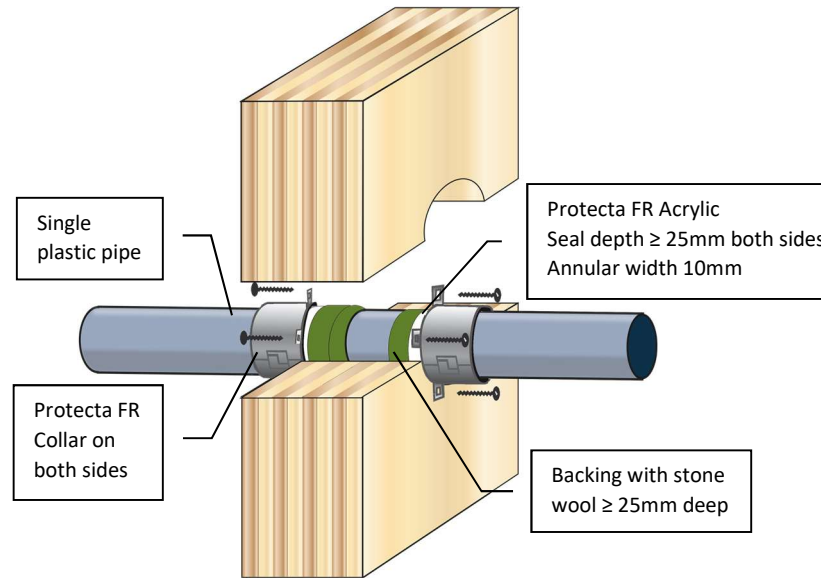

Services	Minimum Collar Height	Classification
≤ Ø50mm PVC-U & PVC-C	30mm	EI 60 C/C, EI 60 U/C, EI 60 C/U, EI 60 U/U (E 90)
≤ Ø110mm PVC-U & PVC-C	30mm	EI 60 C/C, EI 60 U/C
≤ Ø140mm PVC-U & PVC-C	50mm	EI 60 C/C, EI 60 U/C, EI 60 C/U, EI 60 U/U (E 90)
≤ Ø160mm PVC-U & PVC-C	60mm	EI 90 C/C, EI 90 U/C, EI 60 C/U, EI 60 U/U
Ø315x9.2mm PVC-U & PVC-C	75mm	EI 60 C/C
≤ Ø50mm PE, ABS & SAN+PVC	30mm	EI 60 C/C, EI 60 U/C (E 90)
≤ Ø50mm PE, ABS & SAN+PVC	50mm	EI 90 C/C, EI 90 U/C, EI 90 C/U, EI 90 U/U
≤ Ø110mm PE, ABS & SAN+PVC	30mm	EI 60 C/C, EI 60 U/C
≤ Ø110mm PE, ABS & SAN+PVC	50mm	EI 60 C/C, EI 60 U/C, EI 60 C/U, EI 60 U/U (E 90)
≤ Ø140mm PE, ABS & SAN+PVC	60mm	EI 60 C/C, EI 60 U/C, EI 60 C/U, EI 60 U/U (E 90)
Ø160mm PE, ABS & SAN+PVC	60mm	EI 90 C/C, EI 90 U/C, EI 90 C/U, EI 90 U/U
Ø200x18.2mm PE, ABS & SAN+PVC	75mm	EI 60 C/C
Ø250x22.7mm PE, ABS & SAN+PVC	75mm	EI 60 C/C
≤ Ø50mm PP	30mm	EI 60 C/C, EI 60 U/C, EI 60 C/U, EI 60 U/U (E 90)
≤ Ø110mm PP	30mm	EI 60 C/C, EI 60 U/C (E 90)
≤ Ø110mm PP	50mm	EI 60 C/C, EI 60 U/C, EI 60 C/U, EI 60 U/U (E 90)
≤ Ø160mm PP	60mm	EI 60 C/C, EI 60 U/C, EI 60 C/U, EI 60 U/U



Client:

Job Title:

**Products** Protecta FR Collar  
Protecta FR Acrylic  
Stone wool backing ≥ 33 kg/m<sup>3</sup>  
Wood screws ≥ Ø4 x 80mm

**Application** Fire stopping of plastic pipes in timber walls

**Construction** Minimum wall thickness of 100 mm and comprise solid wood or cross-laminated timber

**Fire, Sound and Air classifications**  
Fire classifications in tables on the left. For full pipe specifications, please refer to the Installation Instructions; 100mm thick drywalls.

Reaction to fire (seal only) B-s1,d0

Sound reduction (seal only) Rw 62 dB

Pressure with zero leakage Min. 200 Pa



**Protecta®**

Polyseam Ltd, 15 St Andrews Road,  
Huddersfield, West Yorkshire, HD1 6SB

Tel: +44 (0) 148 4421036

Email: post.uk@polyseam.com

Sheet size: **A4** Drawn date & no: 5/1/20

Scale: **NTS** Drawn by: K.B

As a part of our policy of on-going product development and testing, we reserve the right to modify, alter or change product specifications without giving notice. All information contained in this document is given in good faith and is provided for guidance only. Any drawings provided are for illustrative purposes only. As Polyseam has no control over the methods or competence of installation and of prevailing site conditions, no warranties, expressed or implied, is intended to be given as to the actual performance of the product mentioned or referred to herein and no liability whatsoever will be accepted for any loss, damage or injury arising from the use of the information given.

For all technical details on the products specified please refer to the technical data sheets that can be found on [www.protecta.eu](http://www.protecta.eu)

Signed and approved:

Installation Instructions

1. Before installing Protecta® FR Damper ensure that the surface of surrounding construction is free from all loose contaminants, dust and grease.
2. Install the backing material and lock the Damper in position. Cut this slightly oversize and insert into the gap ensuring a tight friction fit. Ensure correct depth is achieved and that the centre point of the Damper is located mid-depth in the wall.
3. Fill the gap or joint with Protecta® FR Acrylic on both sides to the required depth.
4. Apply the sealant generously to prevent air bubbles. Finish the bead with a moist spatula, pallet knife or brush.
5. Connect the ventilation duct(s) to the damper.
6. Insulate the duct towards the fire seal on both sides with stone wool mat. If the duct is ending in the wall then insulate on one side only.
7. Protecta® FR Acrylic can be over-painted with most emulsion or alkyd (gloss) paints.

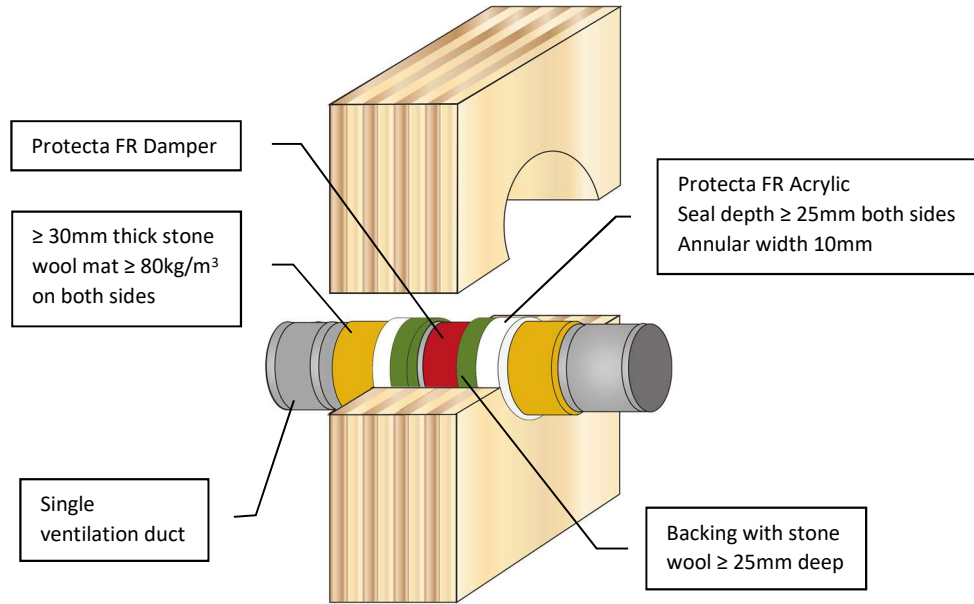

Client:

Job Title:

**Products** Protecta FR Acrylic  
Protecta FR Damper  
Stone wool backing ≥ 33 kg/m<sup>3</sup>

**Application** Fire stopping of ventilation ducts in timber walls

**Construction** Minimum wall thickness of 100 mm and comprise solid wood or cross-laminated timber

**Fire and Sound classifications**

Ventilation duct ≤ Ø400mm with ≥ 200mm stone wool mat EI 90 & E 90

Ventilation duct ≤ Ø1250mm with ≥ 500mm stone wool mat EI 60 & E 90

Sound & Air flow See technical data sheet  
External pressure with zero leakage Min. 200 Pa  
Reaction to fire B-s1,d0



UL-EU-01028-CPR (pending update)

**Protecta®**  
Polyseam Ltd, 15 St Andrews Road,  
Huddersfield, West Yorkshire, HD1 6SB  
Tel: +44 (0) 148 4421036  
Email: post.uk@polyseam.com

As a part of our policy of on-going product development and testing, we reserve the right to modify, alter or change product specifications without giving notice. All information contained in this document is given in good faith and is provided for guidance only. Any drawings provided are for illustrative purposes only. As Polyseam has no control over the methods or competence of installation and of prevailing site conditions, no warranties, expressed or implied, is intended to be given as to the actual performance of the product mentioned or referred to herein and no liability whatsoever will be accepted for any loss, damage or injury arising from the use of the information given.

For all technical details on the products specified please refer to the technical data sheets that can be found on [www.protecta.eu](http://www.protecta.eu)

Signed and approved:

Sheet size: **A4** Drawn date & no: 6/1/20

Scale: **NTS** Drawn by: **K.B**



# INDEX

## Appendix I – Solutions in timber floors

Blank seals to EI 120.....	12
Cables to EI 90.....	13
Cable bundles to EI 90.....	14
Cables and conduits in FR Service Transits to EI 120.....	15
Steel pipes with mineral fibre insulations to EI 60.....	16
Steel pipes with combustible insulations to EI 60.....	17
Copper pipes with mineral fibre insulations to EI 90.....	18
Copper pipes with combustible insulations to EI 45.....	19
Alupex pipes with mineral fibre insulations to EI 90.....	20
Alupes pipes with combustible insulations to EI 90.....	21
Small plastic pipes to EI 120.....	22
Large plastic pipes to EI 60.....	23
Ventilation ducts to EI 90.....	24

## Appendix II – Solutions in timber walls

Blank seals to EI 120.....	26
Cables to EI 45.....	27
Cables to EI 90.....	28
Cable bundles to EI 45.....	29
Cable bundles to EI 60.....	30
Cables and conduits in FR Service Transits to EI 90.....	31
Steel pipes with mineral fibre insulations to EI 60.....	32
Steel pipes with combustible insulations to EI 90.....	33
Copper pipes with mineral fibre insulations to EI 60.....	34
Copper pipes with combustible insulations to EI 90.....	35
Alupex pipes with mineral fibre insulations to EI 90.....	36
Alupes pipes with combustible insulations to EI 90.....	37
Small plastic pipes to EI 90.....	38
Large plastic pipes to EI 60.....	39
Ventilation ducts to EI 90.....	40



## Contact us

### United Kingdom

#### Head Office and Factory

Polyseam Ltd,  
15 St Andrews Road,  
Huddersfield, HD1 6SB.  
United Kingdom.  
T: +44(0) 1484 421036  
E: post.uk@polyseam.com

### Norway

Polyseam AS,  
Ravneveien 7,  
N-3174 Revetal, Norway.  
T: +47 3330 6690  
E: post.no@polyseam.com

### Sweden

Polyseam AB,  
Frukthandlarvägen 7  
120 44 Årsta, Sweden.  
T: +46 (0) 8 124 563 00  
E: post.se@polyseam.com

[www.protecta.eu](http://www.protecta.eu)

